

# sliderM50

## FLEX

**Sistema di scorrimento  
complanare a due ante  
ammortizzato con lunghezza  
del binario personalizzabile  
- portata 50 kg.**

**Coplanar two-door  
cushioned sliding system  
with customisable track length  
- capacity 50 kg per door.**

**Système coulissant coplanaire  
amorti à deux portes avec  
longueur personnalisable du rail  
- portée 50 kg.**

**Flächenbündiges, gedämpftes  
GLEITSYSTEM mit zwei Türen  
mit individuell anpassbarer  
Schienenlänge  
- Tragfähigkeit 50 kg.**

**Sistema de deslizamiento  
coplanario de dos puertas  
amortiguado con longitud  
de la guía personalizable  
- capacidad 50 kg.**

Montaggio  
e regolazione

Assembly and  
adjustments

Montage  
et réglage

Montage und  
Regulierung

Montaje  
y regulación

### [ITA] INDICE

Caratteristiche tecniche .....	3
Contenuto imballi .....	4
Tipologia di montaggio .....	7
Lavorazioni sulla struttura .....	8
Lavorazioni sull'anta .....	12
Taglio dei profili .....	14
Montaggio del meccanismo superiore .....	15
Montaggio del meccanismo inferiore .....	22
Montaggio del meccanismo inferiore sulla struttura .....	29
Montaggio del meccanismo superiore sulla struttura .....	31
Preparazione delle ante .....	33
Messa in bolla del mobile .....	34
Montaggio delle ante .....	34
Regolazione delle ante .....	37
Applicazione del carter copripiedini .....	42
Problemi e soluzioni .....	43

### [ENG] INDEX

Technical features .....	3
Packaging Contents .....	4
Types of assembly .....	7
Drilling and machining the cabinet .....	8
Working on the door .....	12
Cutting the profiles .....	14
Assembling the upper mechanism .....	15
Assembling the lower mechanism .....	22
Installing the lower mechanism onto the cabinet .....	29
Installing the upper mechanism onto the cabinet .....	31
Door preparation .....	33
Unit levelling .....	34
Mounting the door .....	34
Adjusting the door .....	37
Application of the side support feet .....	42
Troubleshooting .....	43

### [FRA] INDEX

Caractéristiques techniques .....	3
Contenus des emballages .....	4
Types de montage .....	7
Usinage du meuble .....	8
Plan de perçage de la porte .....	12
Découpe des profilés hauts .....	14
Montage du mécanisme haut .....	15
Montage du mécanisme bas .....	22
Montage du mécanisme bas sur le meuble .....	29
Montage du mécanisme sur le meuble ..	31
Préparation des portes .....	33
Mise à niveau du meuble .....	34
Montage des portes .....	34
Ajustements des portes .....	37
Mise en place des caches pour les pieds latéraux .....	42
Problèmes et solutions .....	43

### [DEU] INHALTSVERZEICHNIS

Technische Eigenschaften .....	3
Verpackungsinhalt .....	4
Montageart .....	7
Arbeiten am Korpus .....	8
Bearbeitung der Tür .....	12
Zuschneiden der oberen Profile .....	14
Montage des oberen Mechanismus .....	15
Montage des unteren Mechanismus .....	22
Montage des unteren Mechanismus am Korpus .....	29
Montage des oberen Mechanismus am Korpus .....	31
Vorbereitung der Türen .....	33
Möbel ausrichten .....	34
Montage der Türen .....	34
Einstellungen der Türen .....	37
Anbringung der Blende für beide Seitenfüße .....	42
Probleme und Lösungen .....	43

### [ESP] ÍNDICE

Características técnicas .....	3
Relación contenido embalaje .....	4
Tipos de montaje .....	7
Trabajos en la estructura .....	8
Trabajos en la puerta .....	12
Corte de los perfiles .....	14
Montaje del mecanismo superior .....	15
Montaje del mecanismo inferior .....	22
Montaje del mecanismo inferior en la estructura .....	29
Montaje del mecanismo superior en la estructura .....	31
Preparación de las puertas .....	33
Nivelación del mueble .....	34
Montaje de las puertas .....	34
Ajustes de las puertas .....	37
Aplicación del cárter cubrepatas .....	42
Problemas y soluciones .....	43

[ITA] **CARATTERISTICHE TECNICHE**

**COMPOSIZIONE MECCANISMO**

- › Profili in alluminio: lega 6060T5, anodizzati argento.
- › Ruote di scorrimento: cuscinetti per alta velocità.
- › Componenti: pressofusi in zama primaria 15, laminati in acciaio, elementi in plastica.

**CARATTERISTICHE ANTE**

- › Peso massimo per singola anta 50 kg (uniformemente distribuito).
- › Larghezza:
  - minimo 800 mm;
  - massimo 1600 mm.
- › Altezza: - massimo 2700 mm.
- › Spessore: - minimo 18 mm;
- massimo con maniglia 40 mm.
- › Altezza da terra:
  - 33 mm.
- › Materiale: a) legno o derivati;
- b) telaio in metallo e vetro.
- › Regolazione dell'anta:
  - verticale  $\pm 5,0$  mm;
  - orizzontale  $\pm 3,5$  mm.
- › Regolazione frontale dell'anta:
  - superiore  $\pm 3,0$  mm;
  - inferiore  $\pm 3,0$  mm.

**TIPOLOGIE APERTURE**

- › L'apertura delle ante è prevista tramite l'ausilio di maniglie posizionate al centro del mobile.

[ENG] **TECHNICAL FEATURES**

**FEATURES OF THE MECHANISM**

- › Aluminium profiles: 6060T5 alloy, silver anodised.
- › Rollers: high-velocity bearings.
- › Components: in primary zamak 15, coated steel, plastic.

**DOOR FEATURES**

- › Maximum weight for each door 50 kg (evenly distributed).
- › Width:
  - minimum 800 mm,
  - maximum 1600 mm.
- › Height: - maximum 2700 mm.
- › Thickness:
  - minimum 18 mm,
  - maximum with handle 40 mm.
- › Height from the ground:
  - 33 mm.
- › Material: a) wood or derived material;
- b) glass with metal frame.
- › Door adjustment:
  - vertical  $\pm 5.0$  mm,
  - horizontal  $\pm 3.5$  mm.
- › Door front adjustment:
  - upper  $\pm 3.0$  mm,
  - lower  $\pm 3.0$  mm.

**TYPES OF OPENING**

- › The doors are opened by means of handles fitted at the centre of the unit.

[DEU] **TECHNISCHE EIGENSCHAFTEN**

**ZUSAMMENSETZUNG DES MECHANISMUS**

- › Profile aus Aluminium: Legierung 6060T5, eloxiert, silber.
- › Laufräder: Hochgeschwindigkeit-Lager.
- › Bauteile: 15-Zamakdruckguss, Stahlblech, Kunststoff.

**EIGENSCHAFTEN DER TÜREN**

- › Maximales Gewicht pro Tür 50 kg (gleichmäßig verteilt).
- › Breite:
  - min. 800 mm,
  - max. 1600 mm.
- › Höhe: - max. 2700 mm.
- › Stärke:
  - min. 18 mm,
  - max. incl. Griff 40 mm.
- › Höhe ab dem Boden:
  - 33 mm.
- › Material: a) Holz oder Holzprodukte;
- b) Rahmen aus Metall oder Glas.
- › Regulierung der Tür:
  - vertikal  $\pm 5,0$  mm;
  - horizontal  $\pm 3,5$  mm.
- › Front-Regulierung der Tür:
  - oben  $\pm 3,0$  mm;
  - unten  $\pm 3,0$  mm.

**ÖFFNUNGSTYPEN**

- › Die Öffnung der Türen ist mithilfe von Griffen, die sich in der Mitte des Möbelstücks befinden, vorgesehen.

[FRA] **CARACTÉRISTIQUES TECHNIQUES**

**COMPOSITION DU MÉCANISME**

- › Profilés en aluminium : alliage 6060T5 anodisés argent.
- › Roulettes de coulissement : roulements pour grande vitesse.
- › Composants : zamak 15 primaire, acier laminé, éléments en plastique.

**CARACTÉRISTIQUES DES PORTES**

- › Poids maximum par porte 50 kg (Réparti de manière uniforme).
- › Largeur :
  - minimale 800 mm ;
  - maximale 1600 mm.
- › Hauteur :
  - maximale 2700 mm.
- › Épaisseur :
  - minimale 18 mm ;
  - maximale avec poignée 40 mm.
- › Hauteur du sol :
  - 33 mm.
- › Matériau :
  - a) bois ou produits dérivés ;
  - b) cadre en métal ou en verre.
- › Réglage de la porte :
  - vertical  $\pm 5,0$  mm ;
  - horizontal  $\pm 3,5$  mm.
- › Réglage avant de la porte :
  - supérieur  $\pm 3,0$  mm ;
  - inférieur  $\pm 3,0$  mm.

**TYPES D'OUVERTURES**

- › L'ouverture des portes est prévue grâce à des poignées placées au centre du meuble.

[ESP] **CARACTERÍSTICAS TÉCNICAS**

**COMPOSICIÓN DEL MECANISMO**

- › Perfiles de aluminio: aleación 6060T5, anodizados en plata.
- › Ruedas de deslizamiento: cojinetes para alta velocidad.
- › Componentes: aleaciones primarias de zinc y aluminio 15, laminados de acero, elementos de plástico.

**CARACTERÍSTICAS DE LAS PUERTAS**

- › Peso máximo para cada puerta 50 kg (uniformemente distribuido).
- › Anchura:
  - mínimo 800 mm;
  - máximo 1600 mm.
- › Altura: - máximo 2700 mm.
- › Espesor:
  - mínimo 18 mm;
  - máximo con manilla 40 mm.
- › Altura desde el suelo:
  - 33 mm.
- › Material: a) madera o derivados;
- b) bastidor de metal y vidrio.
- › Regulación de la puerta:
  - vertical  $\pm 5,0$  mm;
  - horizontal  $\pm 3,5$  mm.
- › Regulación frontal de la puerta:
  - superior  $\pm 3,0$  mm;
  - inferior  $\pm 3,0$  mm.

**TIPOLOGÍAS DE APERTURAS**

- › La apertura de las puertas se realiza mediante la ayuda de manillas colocadas en el centro del mueble.

[ITA] CONTENUTO IMBALLI

[ENG] PACKAGING CONTENTS

[FRA] CONTENUS DES EMBALLAGES

[DEU] VERPACKUNGSIHALT

[ESP] RELACIÓN CONTENIDO EMBALAJE

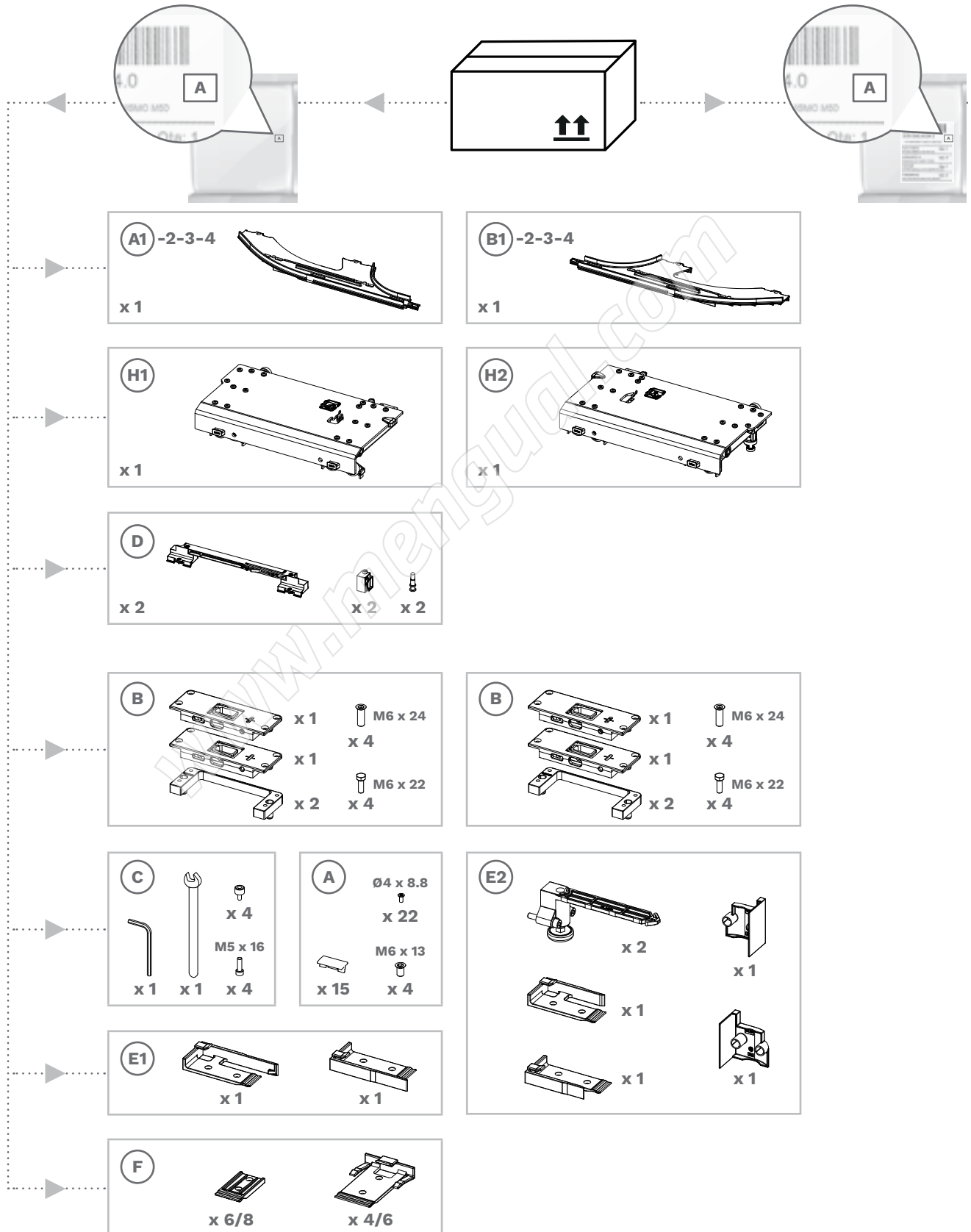

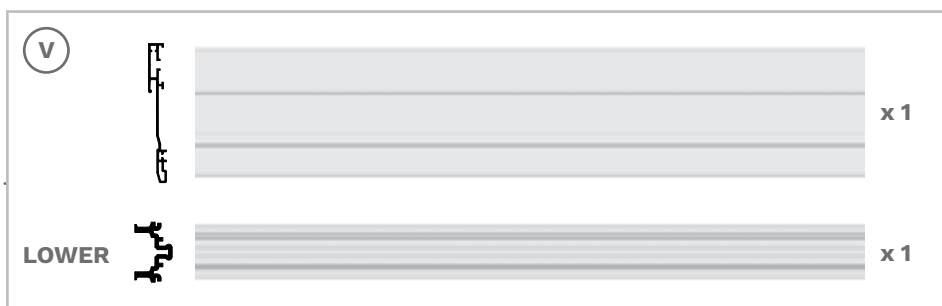
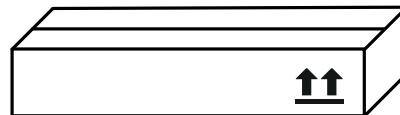
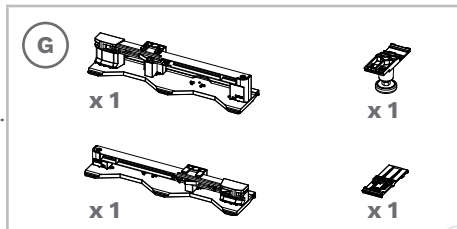
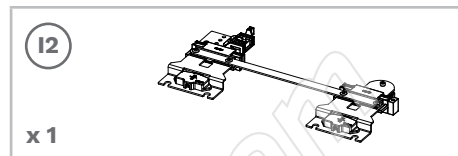
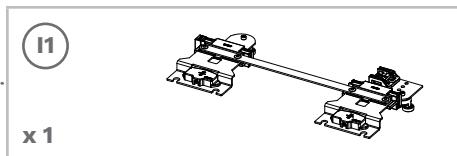
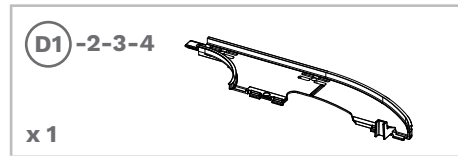
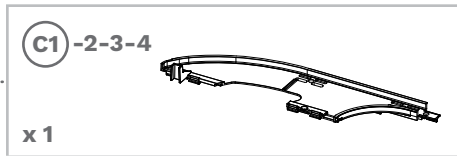

# sliderM50

FLEX

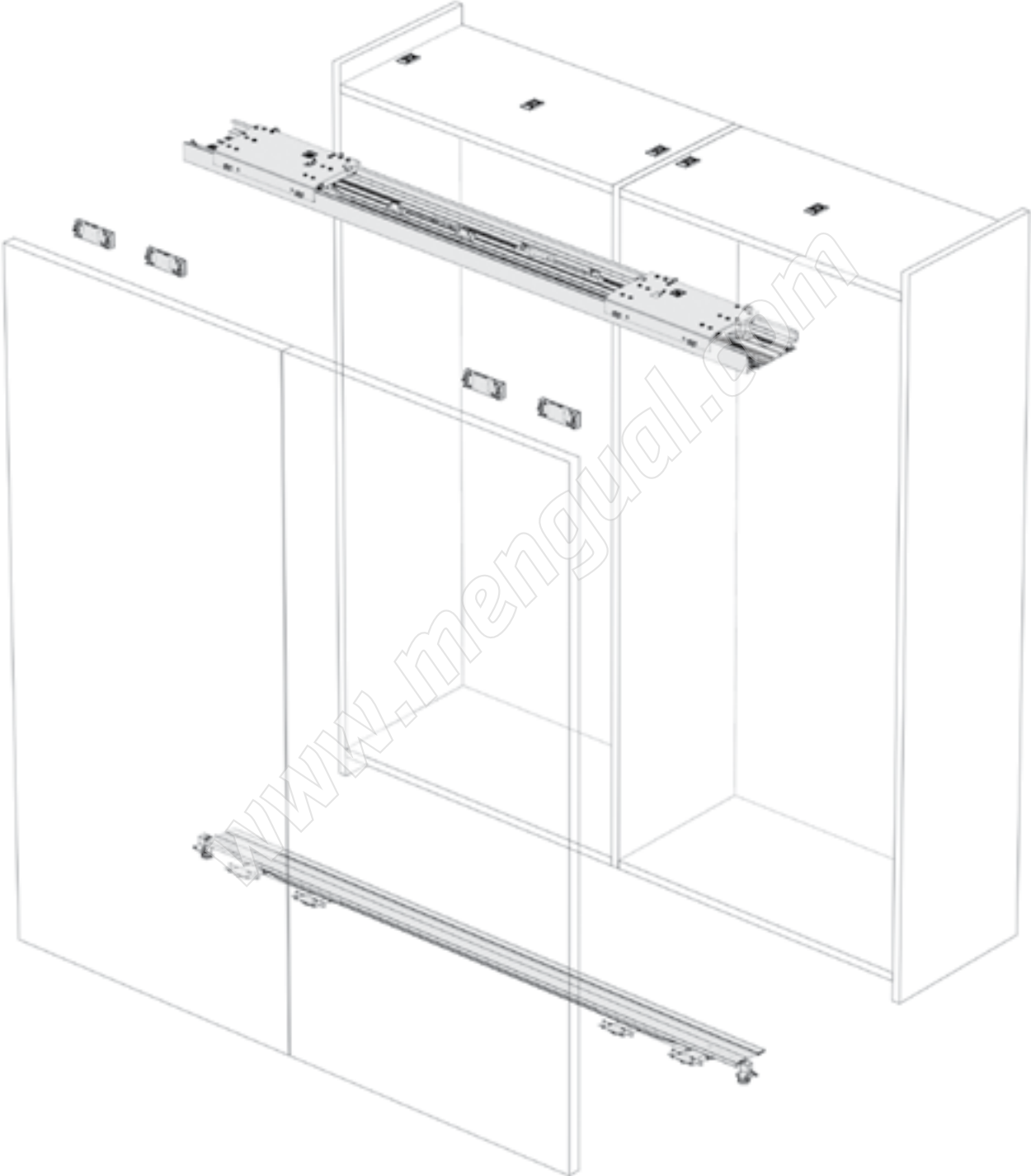

[ITA] TIPOLOGIA DI MONTAGGIO

[ENG] TYPES OF ASSEMBLY

[FRA] TYPES DE MONTAGE

[DEU] MONTAGEART

[ESP] TIPOS DE MONTAJE

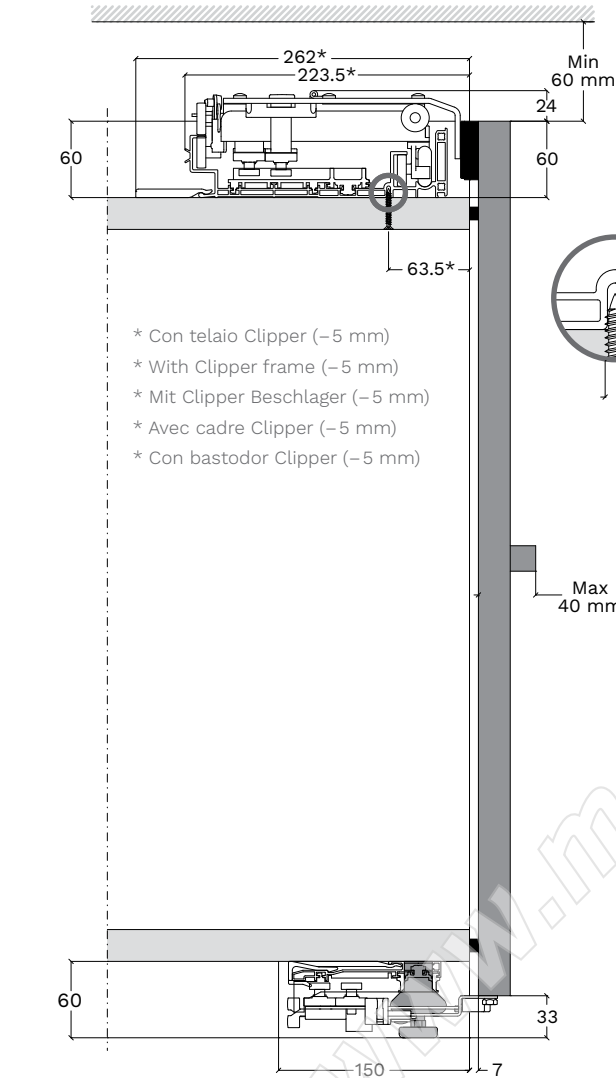

- \* Con telaio Clipper (-5 mm)
- \* With Clipper frame (-5 mm)
- \* Mit Clipper Beschlager (-5 mm)
- \* Avec cadre Clipper (-5 mm)
- \* Con bastodor Clipper (-5 mm)

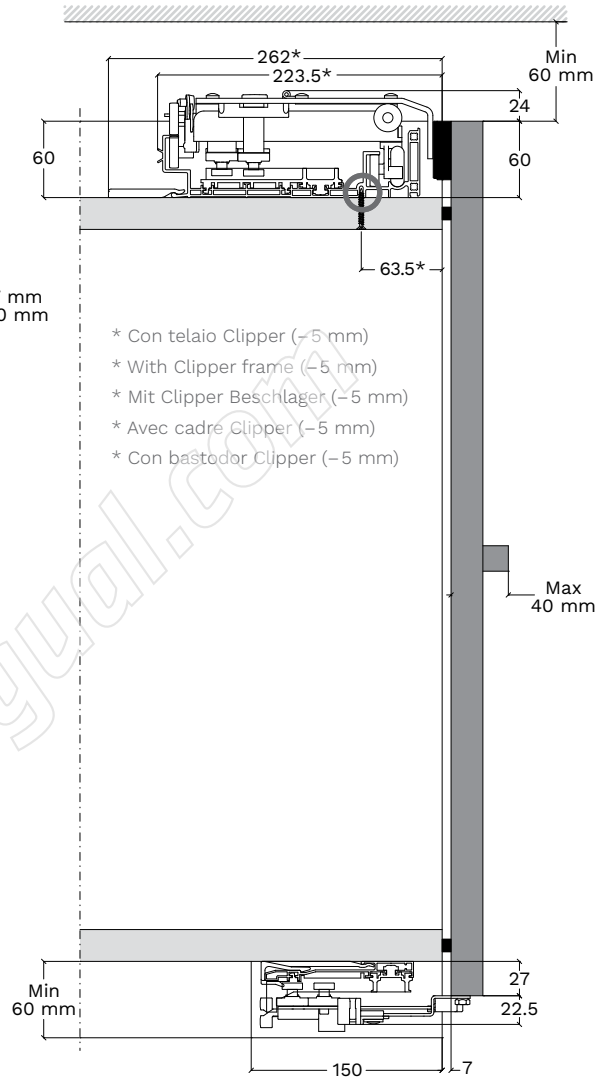

- \* Con telaio Clipper (-5 mm)
- \* With Clipper frame (-5 mm)
- \* Mit Clipper Beschlager (-5 mm)
- \* Avec cadre Clipper (-5 mm)
- \* Con bastodor Clipper (-5 mm)

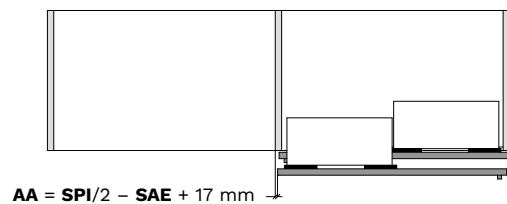
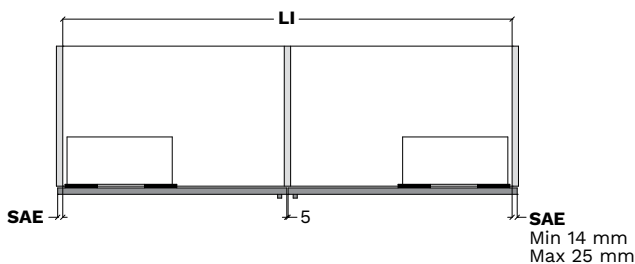
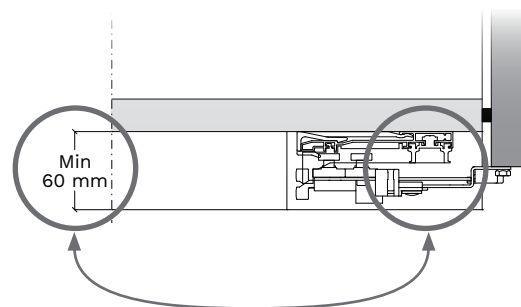
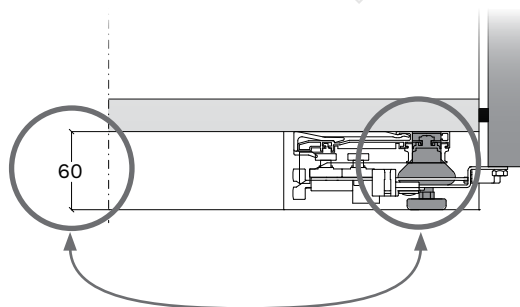

[ITA] LAVORAZIONI SULLA STRUTTURA  
LI 1531-2330 MM (CON PIEDINI)

[ENG] DRILLING AND MACHINING THE  
CABINET LI 1531-2330 MM (WITH FEET)

[FRA] USINAGE DU MEUBLE  
LI 1531-2330 MM (AVEC PIEDS)

[DEU] ARBEITEN AM KORPUS  
LI 1531-2330 MM (MIT FÜSSE)

[ESP] TRABAJOS EN LA ESTRUCTURA  
LI 1531-2330 MM (CON PIES)

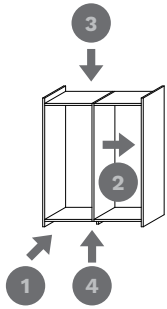

- \* Con telaio Clipper (-5 mm)
- \* With Clipper frame (-5 mm)
- \* Mit Clipper Beschläger (-5 mm)
- \* Avec cadre Clipper (-5 mm)
- \* Con bastodor Clipper (-5 mm)

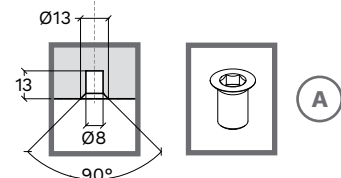
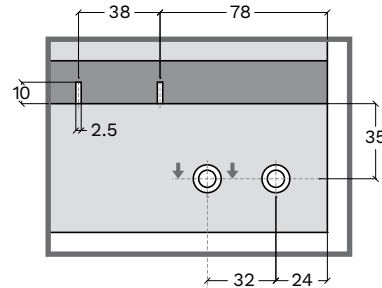
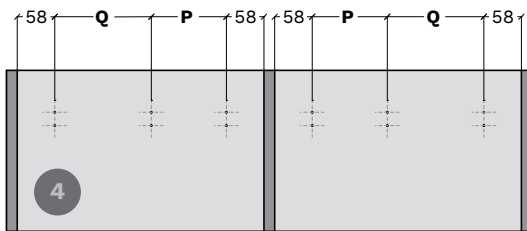
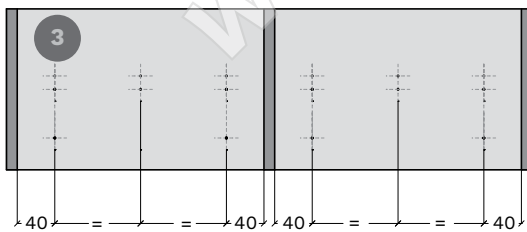
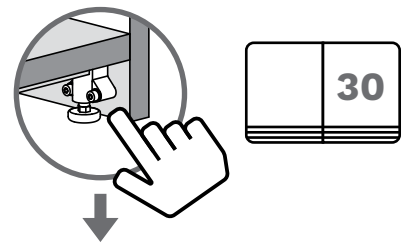
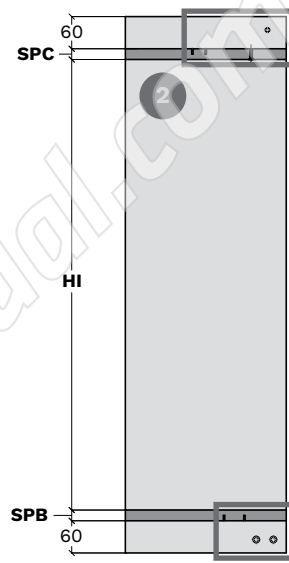
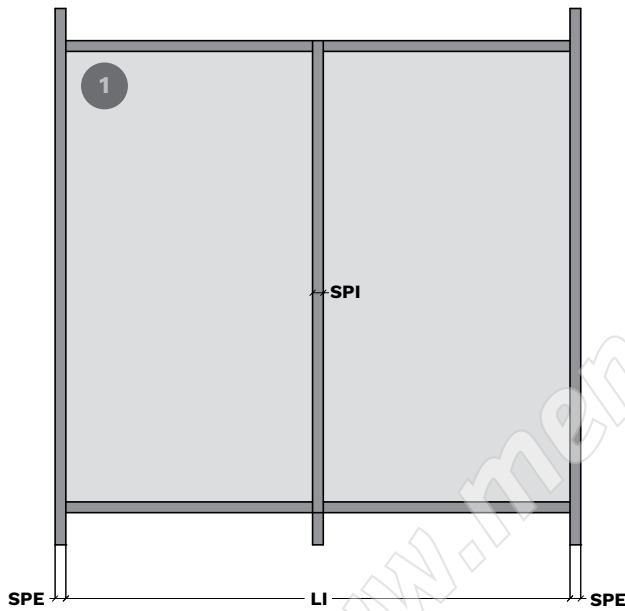
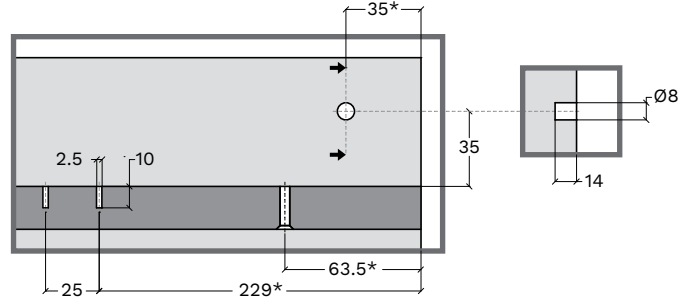

P	LI/4 - SPI/2 - 70 mm
Q	LI/4 - 46 mm

[ITA] LAVORAZIONI SULLA STRUTTURA  
LI 1531-2330 MM (SENZA PIEDINI)

[ENG] DRILLING AND MACHINING THE  
CABINET LI 1531-2330 MM (WITHOUT FEET)

[FRA] USINAGE DU MEUBLE  
LI 1531-2330 MM (SANS PIEDS)

[DEU] ARBEITEN AM KORPUS  
LI 1531-2330 MM (OHNE FÜSSE)

[ESP] TRABAJOS EN LA ESTRUCTURA  
LI 1531-2330 MM (SIN PIES)

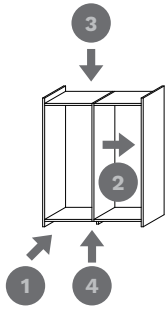

- \* Con telaio Clipper (-5 mm)
- \* With Clipper frame (-5 mm)
- \* Mit Clipper Beschlager (-5 mm)
- \* Avec cadre Clipper (-5 mm)
- \* Con bastodor Clipper (-5 mm)

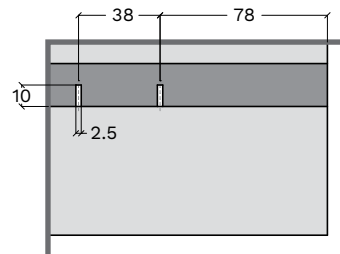
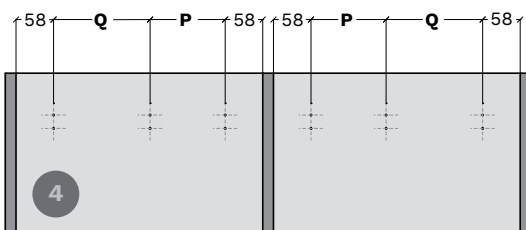
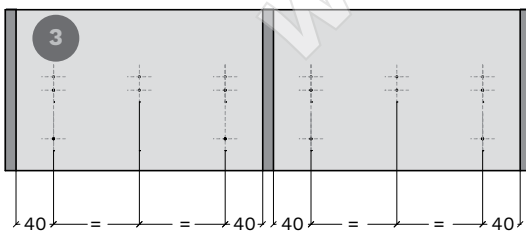
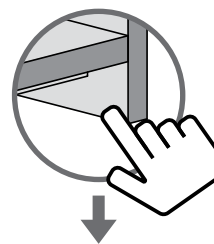
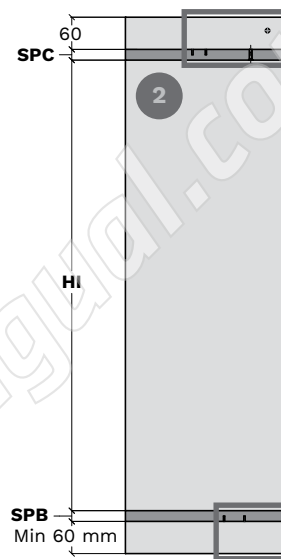
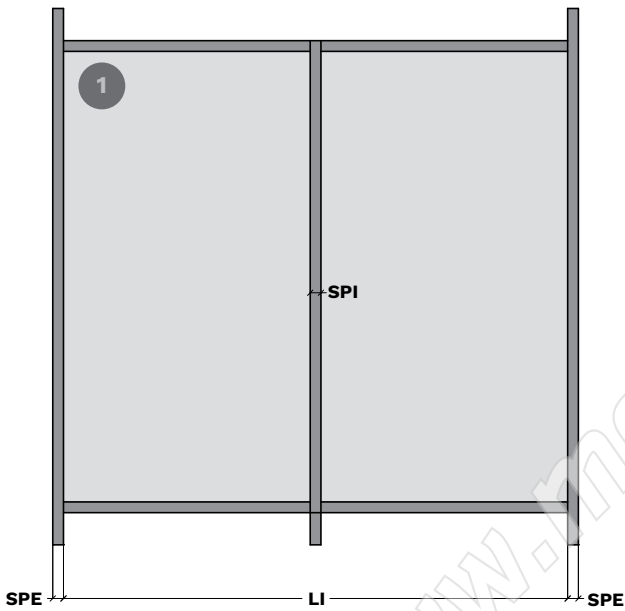
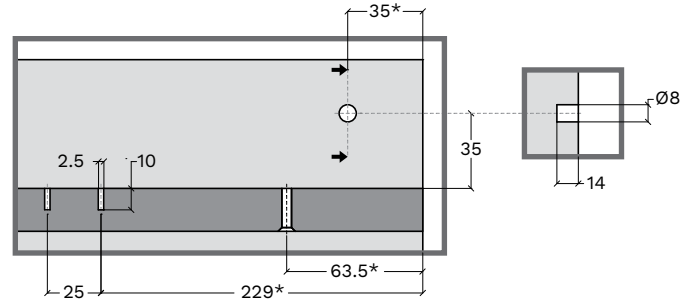

P	LI/4 - SPI/2 - 70 mm
Q	LI/4 - 46 mm

[ITA] LAVORAZIONI SULLA STRUTTURA  
LI 2331-3200 MM (CON PIEDINI)

[ENG] DRILLING AND MACHINING THE  
CABINET LI 2331-3200 MM (WITH FEET)

[FRA] USINAGE DU MEUBLE  
LI 2331-3200 MM (AVEC PIEDS)

[DEU] ARBEITEN AM KORPUS  
LI 2331-3200 MM (MIT FÜSSE)

[ESP] TRABAJOS EN LA ESTRUCTURA  
LI 2331-3200 MM (CON PIES)

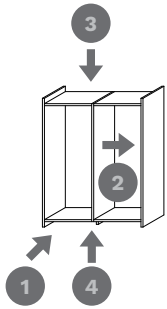

- \* Con telaio Clipper (-5 mm)
- \* With Clipper frame (-5 mm)
- \* Mit Clipper Beschläger (-5 mm)
- \* Avec cadre Clipper (-5 mm)
- \* Con bastodor Clipper (-5 mm)

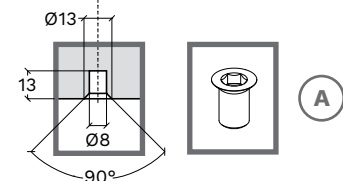
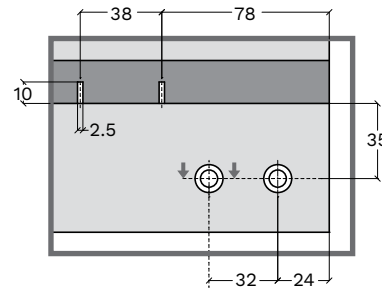
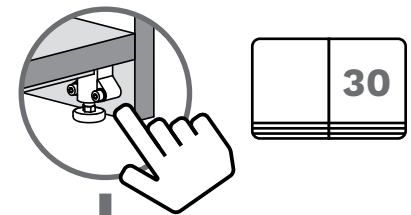
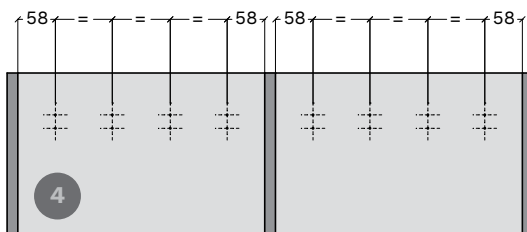
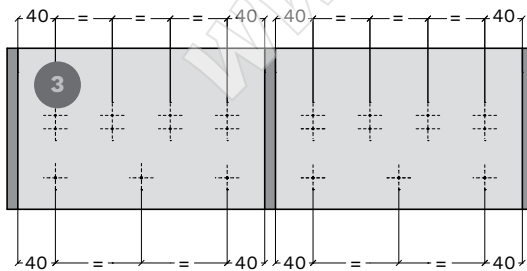
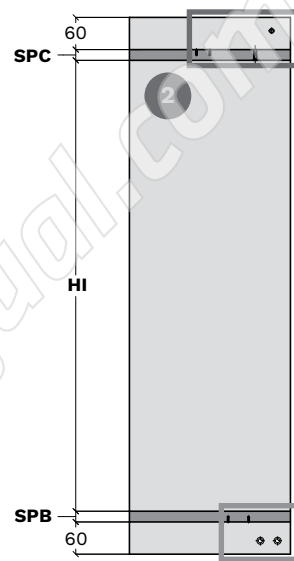
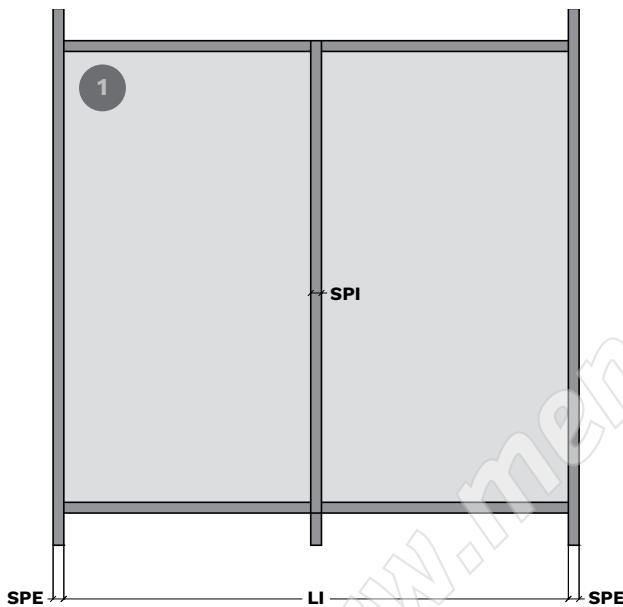
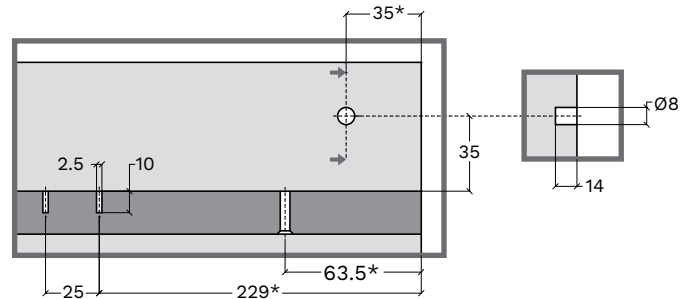

[ITA] LAVORAZIONI SULLA STRUTTURA  
LI 2331-3200 MM (SENZA PIEDINI)

[ENG] DRILLING AND MACHINING THE  
CABINET LI 2331-3200 MM (WITHOUT FEET)

[FRA] USINAGE DU MEUBLE  
LI 2331-3200 MM (SANS PIEDS)

[DEU] ARBEITEN AM KORPUS  
LI 2331-3200 MM (OHNE FÜSSE)

[ESP] TRABAJOS EN LA ESTRUCTURA  
LI 2331-3200 MM (SIN PIES)

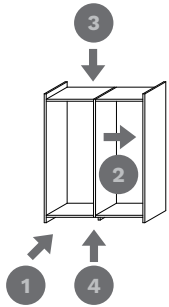

- \* Con telaio Clipper (-5 mm)
- \* With Clipper frame (-5 mm)
- \* Mit Clipper Beschläger (-5 mm)
- \* Avec cadre Clipper (-5 mm)
- \* Con bastodor Clipper (-5 mm)

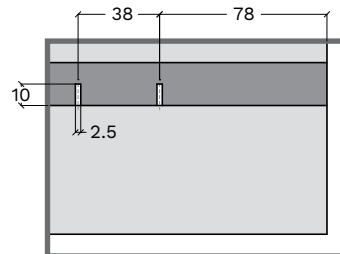
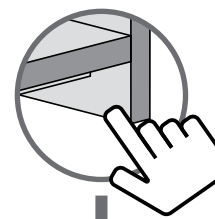
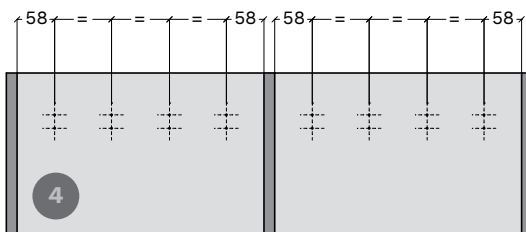
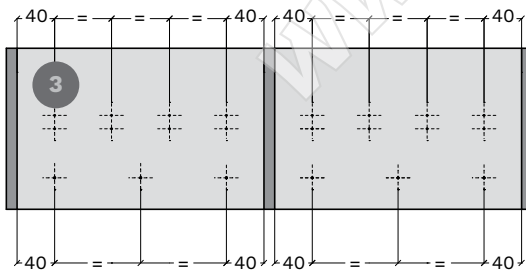
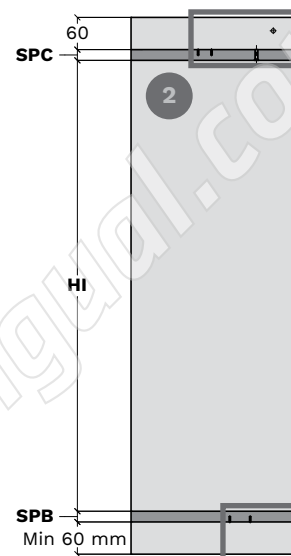
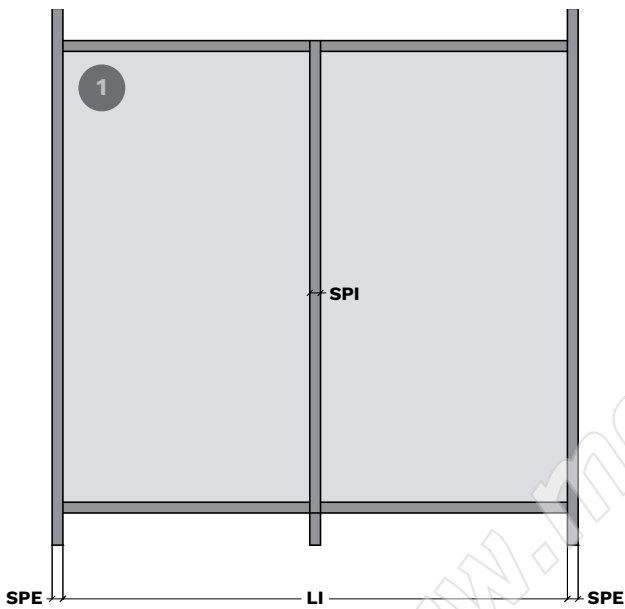
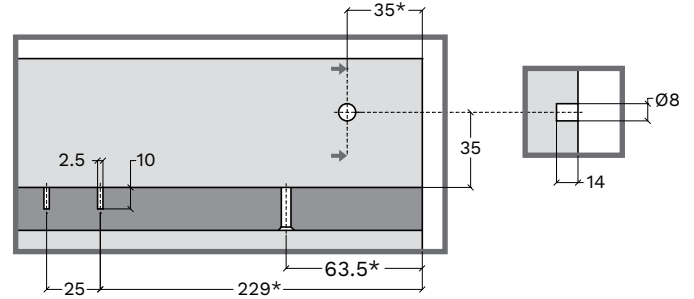

[ITA] LAVORAZIONI SULL'ANTA SINISTRA

[ENG] WORKING ON THE DOOR LEFT

[FRA] PLAN DE PERÇAGE DE LA PORTE GAUCHE

[DEU] BEARBEITUNG DER TÜR LINKS

[ESP] TRABAJOS EN LA PUERTA IZQUIERDA

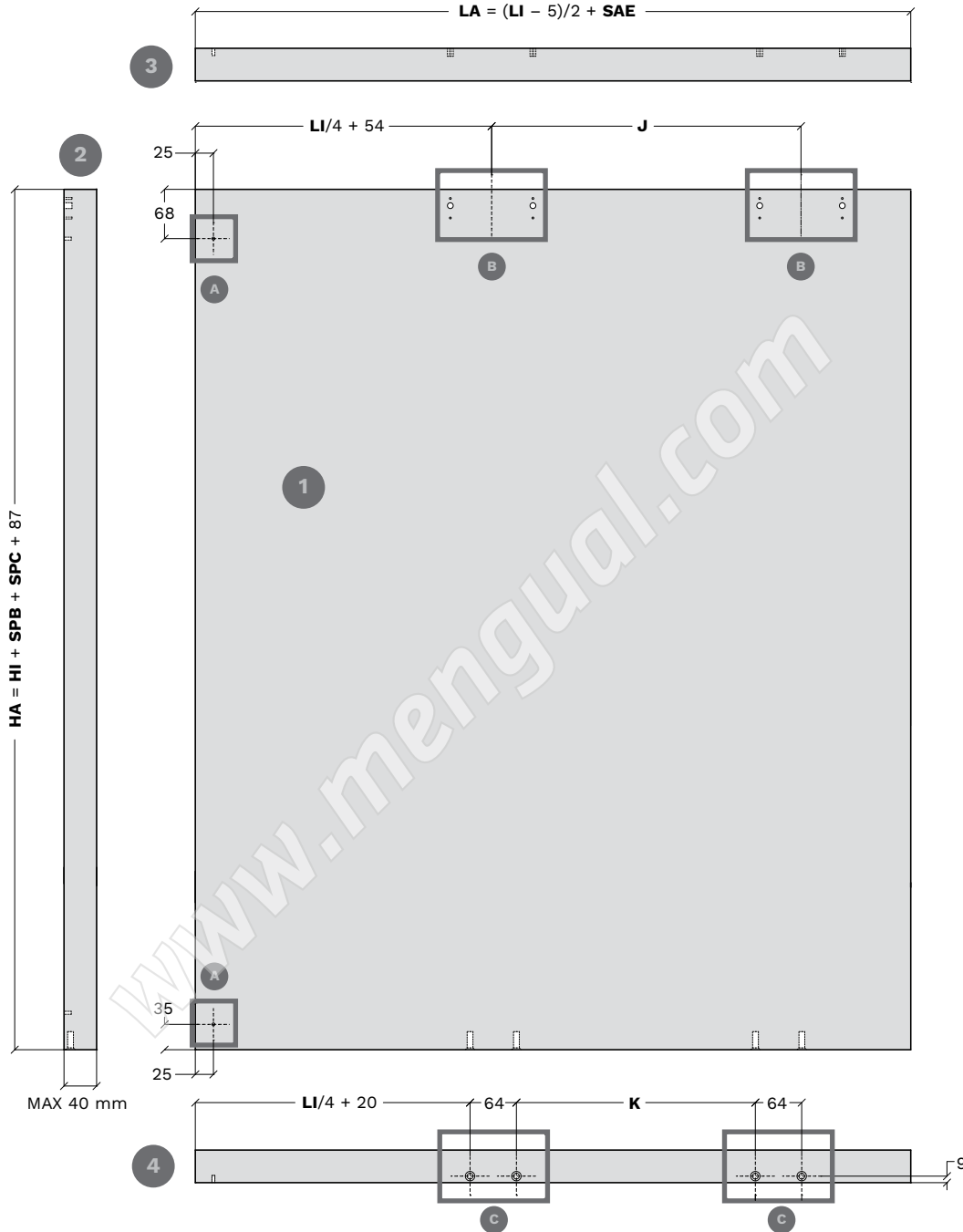
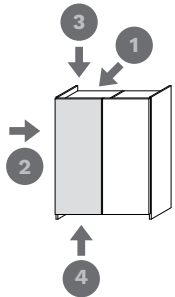

LI (mm)	J (mm)	K (mm)
1531-1930	254	177
1931-2330	354	277
2331-2730	454	377
2731-3200	554	477

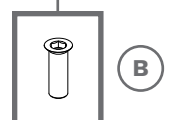
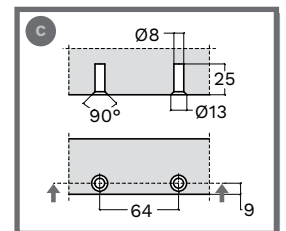
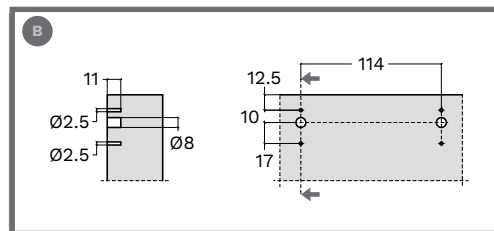
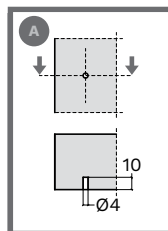

[ITA] LAVORAZIONI SULL'ANTA DESTRA

[ENG] WORKING ON THE DOOR RIGHT

[FRA] PLAN DE PERÇAGE DE LA PORTE DROIT

[DEU] BEARBEITUNG DER TÜR RECHTS

[ESP] TRABAJOS EN LA PUERTA DERECHA

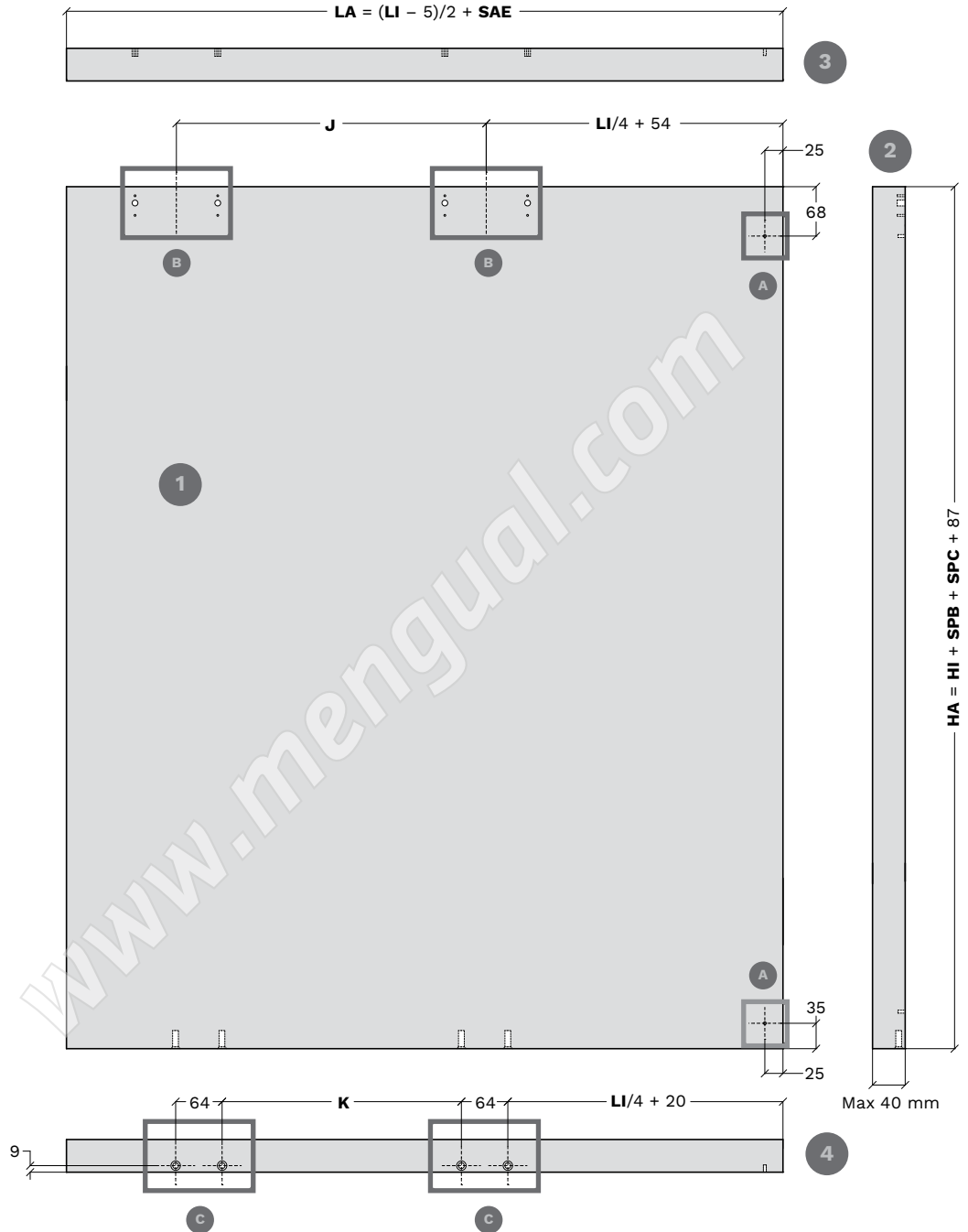
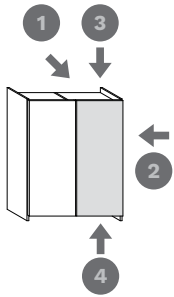

LI (mm)	J (mm)	K (mm)
1531-1930	254	177
1931-2330	354	277
2331-2730	454	377
2731-3200	554	477

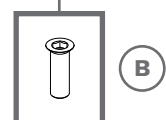
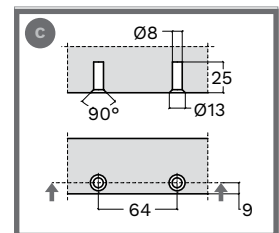
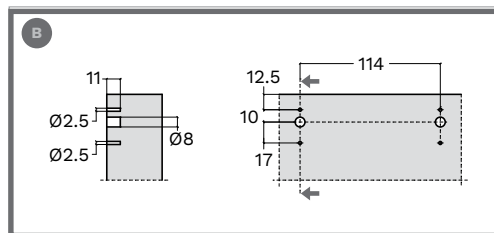
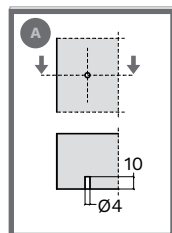

[ITA] TAGLIO DEI PROFILI SUPERIORI

[ENG] CUTTING THE UPPER PROFILES

[FRA] DÉCOUPE DES PROFILÉS HAUTS

[DEU] ZUSCHNEIDEN DER OBEREN PROFILE

[ESP] CORTE DE LOS PERFILES SUPERIORES

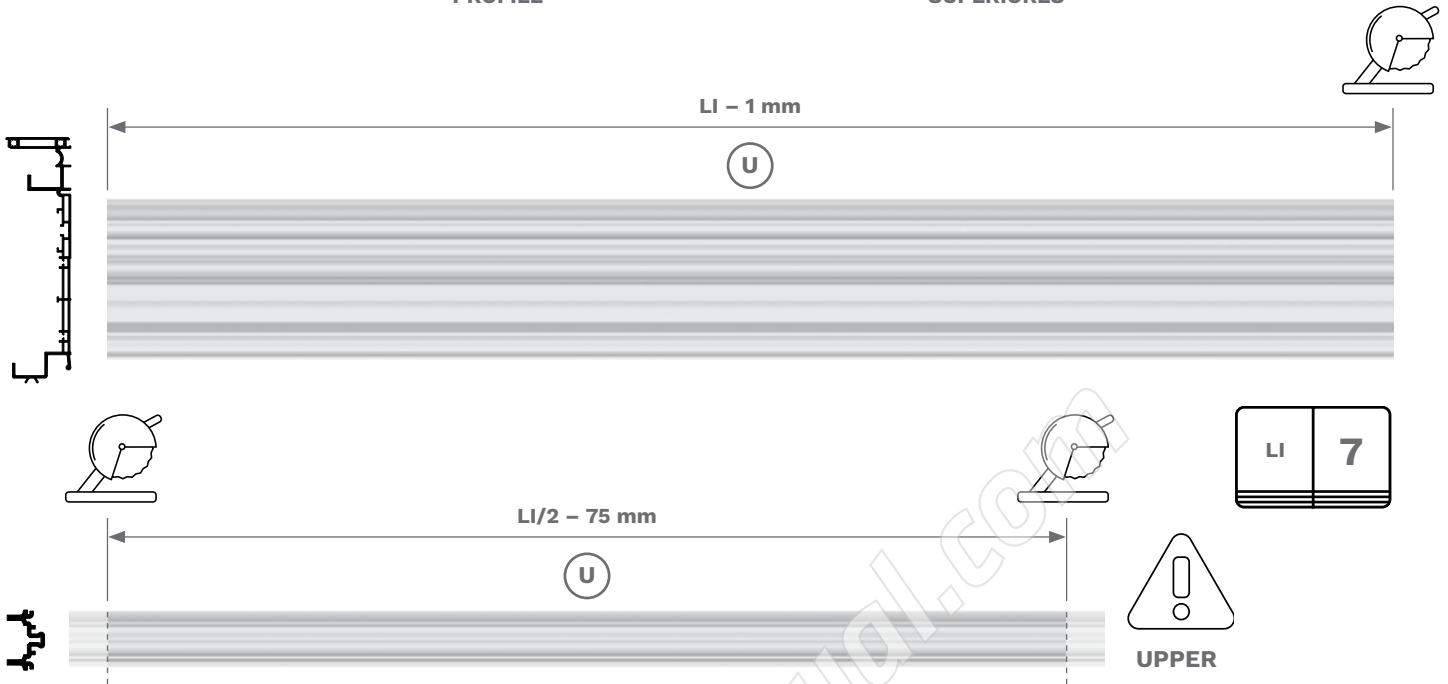

[ITA] TAGLIO DEI PROFILI INFERIORI

[ENG] CUTTING THE LOWER PROFILES

[FRA] DÉCOUPE DES PROFILÉS BAS

[DEU] ZUSCHNITT DER UNTEREN PROFILE

[ESP] CORTE DE LOS PERFILES INFERIORES

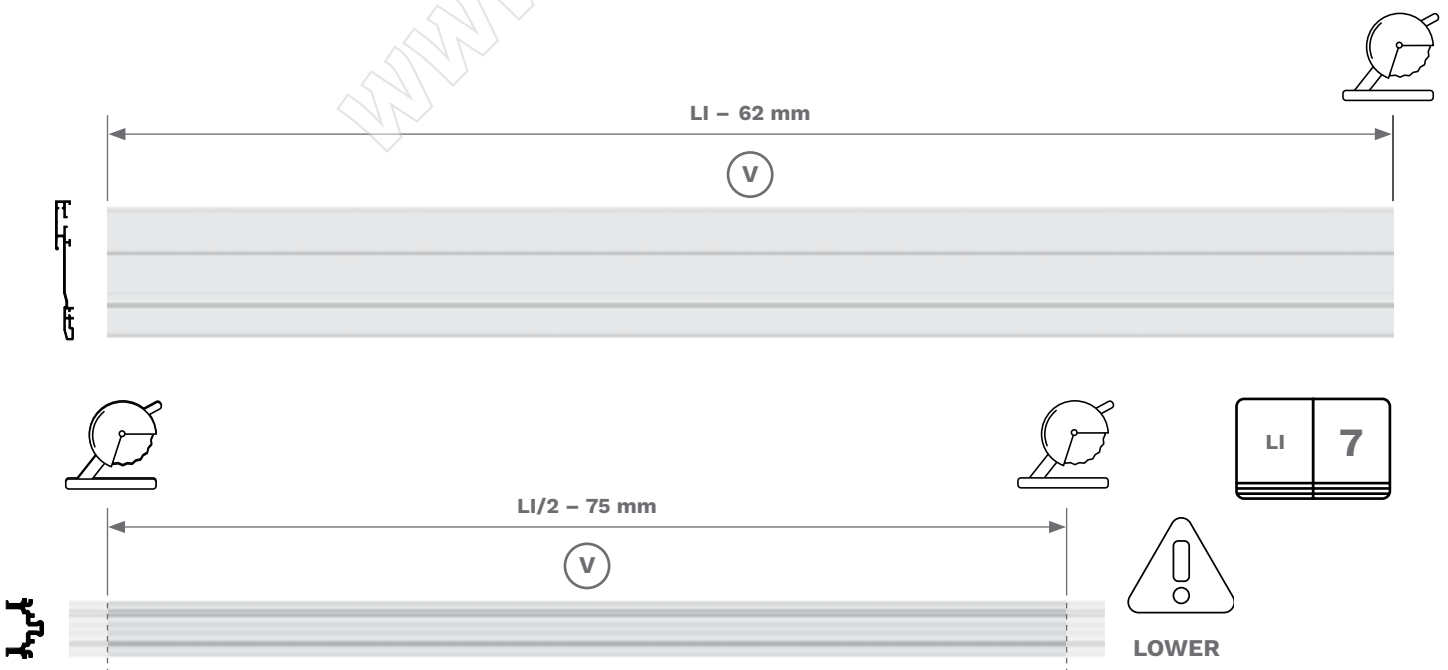

[ITA] MONTAGGIO  
DEL MECCANISMO SUPERIORE

[ENG] ASSEMBLING THE UPPER  
MECHANISM

[FRA] MONTAGE DU MÉCANISME HAUT



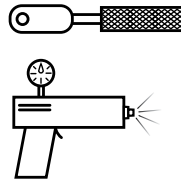
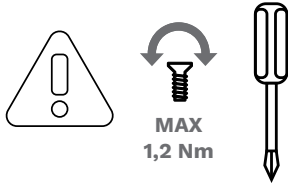

[DEU] MONTAGE DES OBEREN  
MECHANISMUS

[ESP] MONTAJE DEL MECANISMO  
SUPERIOR

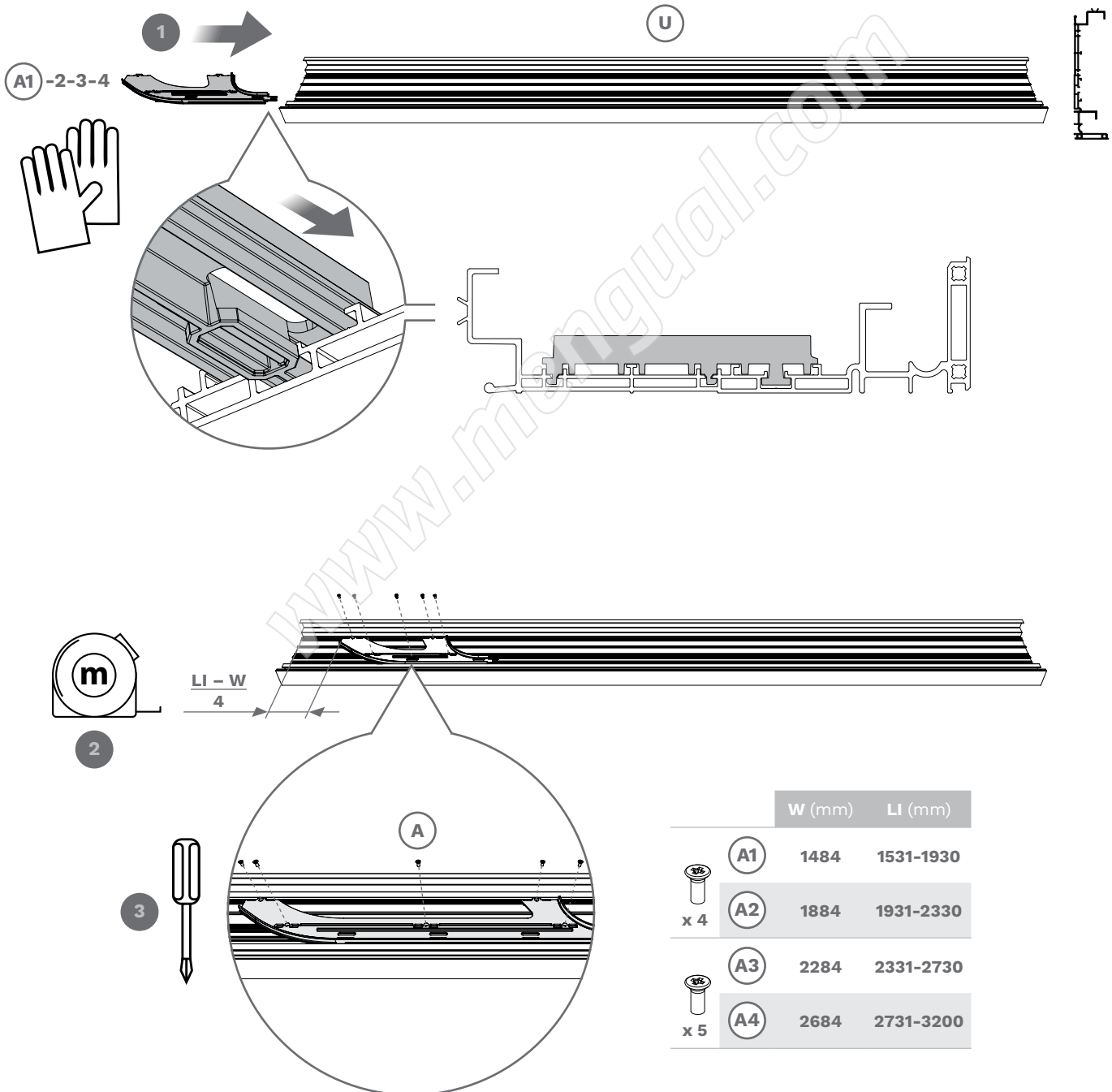

Rimuovere accuratamente tutti i residui di taglio.  
Accurately remove all cutting residues.  
Sorgfältig alle Schnittrückstände entfernen.  
Enlever soigneusement tous les résidus de découpe.  
Eliminar atentamente todos los residuos de la operación de corte.



	W (mm)	LI (mm)
 <b>A1</b>	1484	1531-1930
 <b>A2</b>	1884	1931-2330
 <b>A3</b>	2284	2331-2730
 <b>A4</b>	2684	2731-3200

[ITA] MONTAGGIO  
DEL MECCANISMO SUPERIORE

[ENG] ASSEMBLING THE UPPER  
MECHANISM

[FRA] MONTAGE DU MÉCANISME HAUT

[ESP] MONTAJE DEL MECANISMO  
SUPERIOR

[DEU] MONTAGE DES OBEREN  
MECHANISMUS

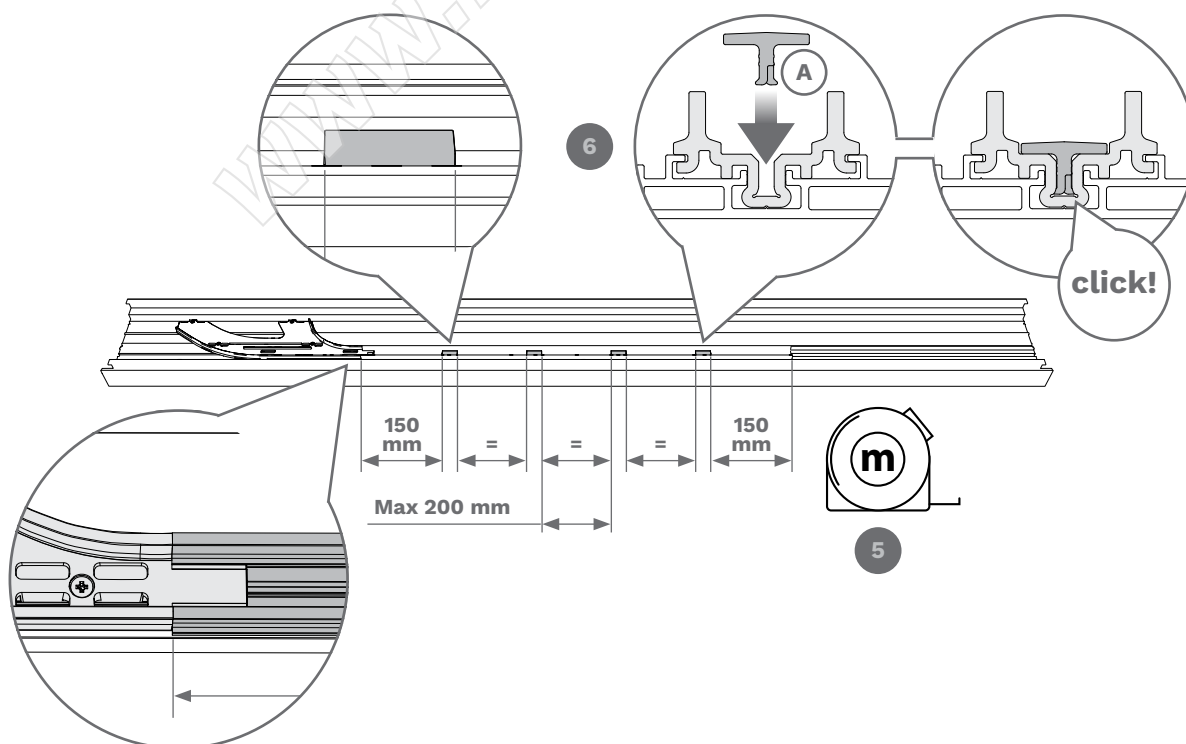
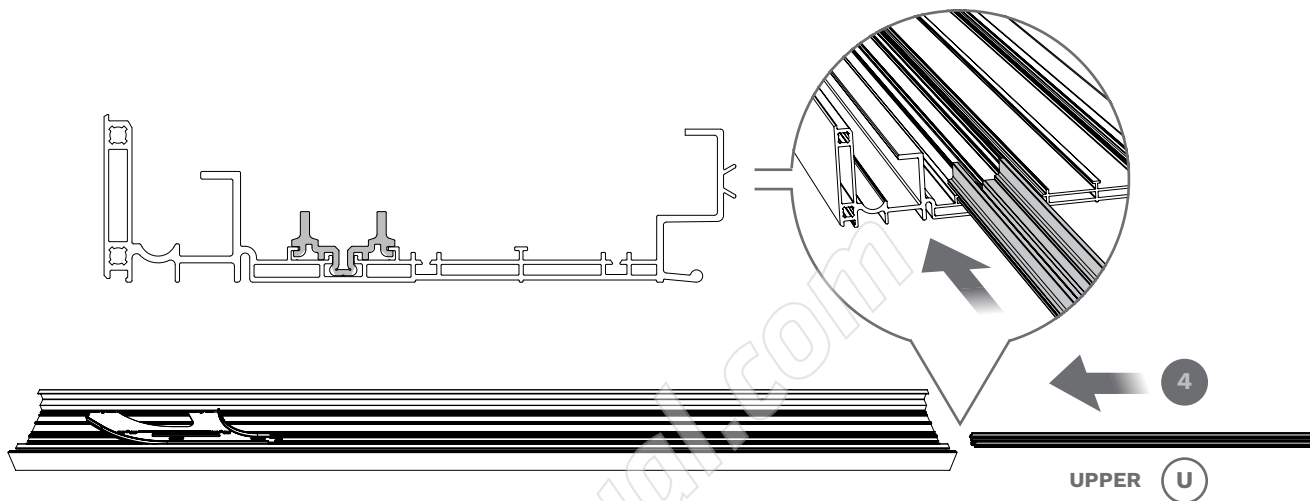

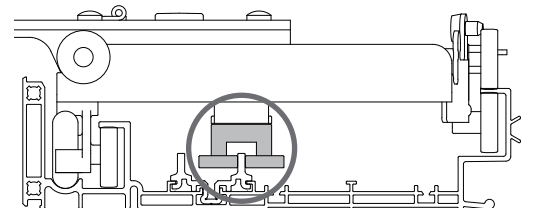
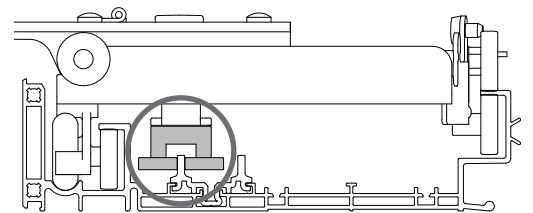
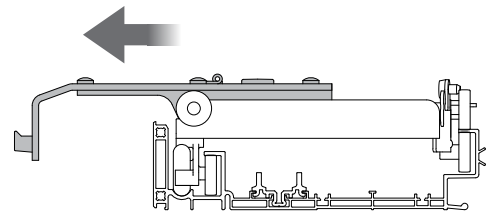
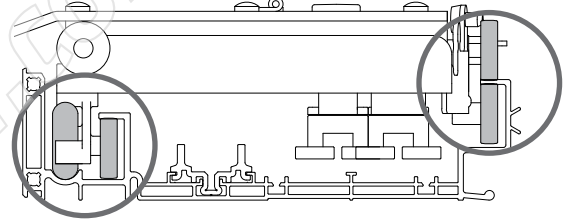
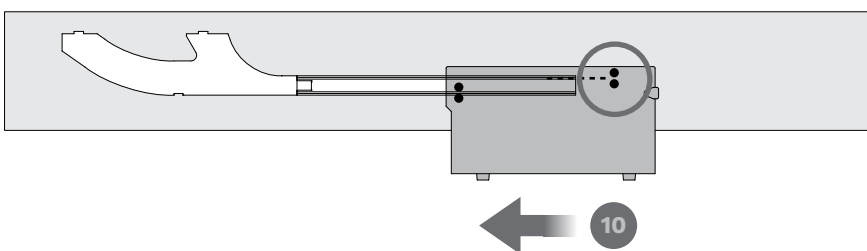
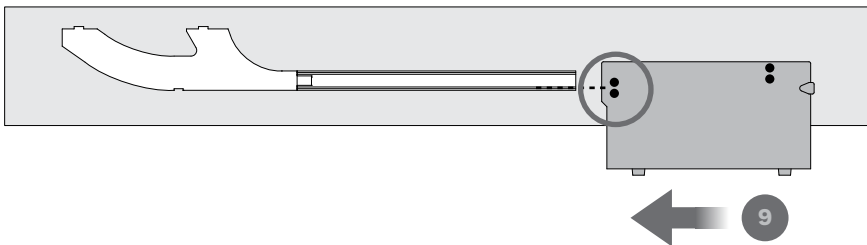
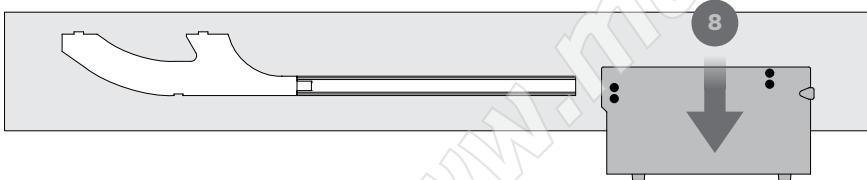
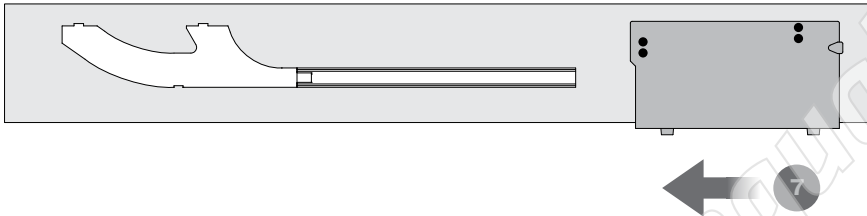
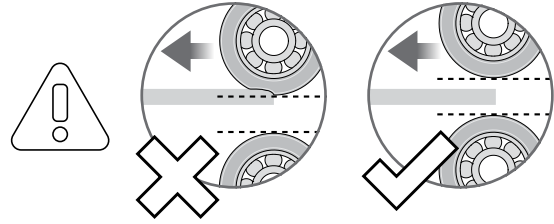

[ITA] MONTAGGIO  
DEL MECCANISMO SUPERIORE

[ENG] ASSEMBLING THE UPPER  
MECHANISM

[FRA] MONTAGE DU MÉCANISME HAUT

[ESP] MONTAJE DEL MECANISMO  
SUPERIOR

[DEU] MONTAGE DES OBEREN  
MECHANISMUS

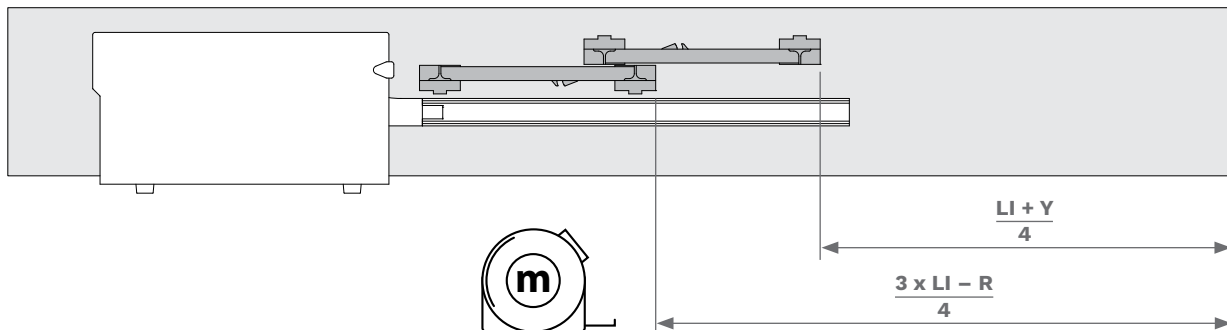
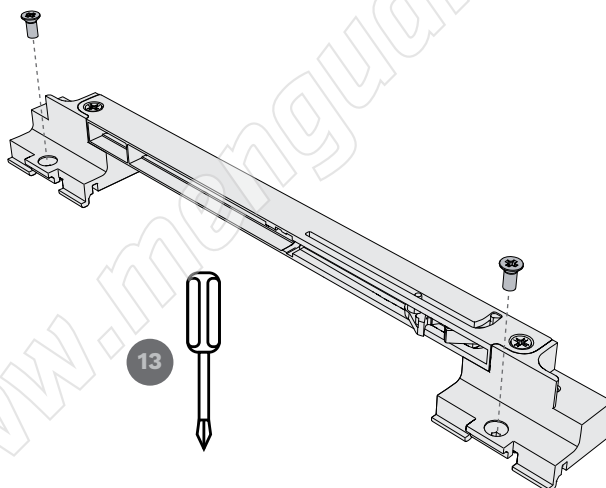
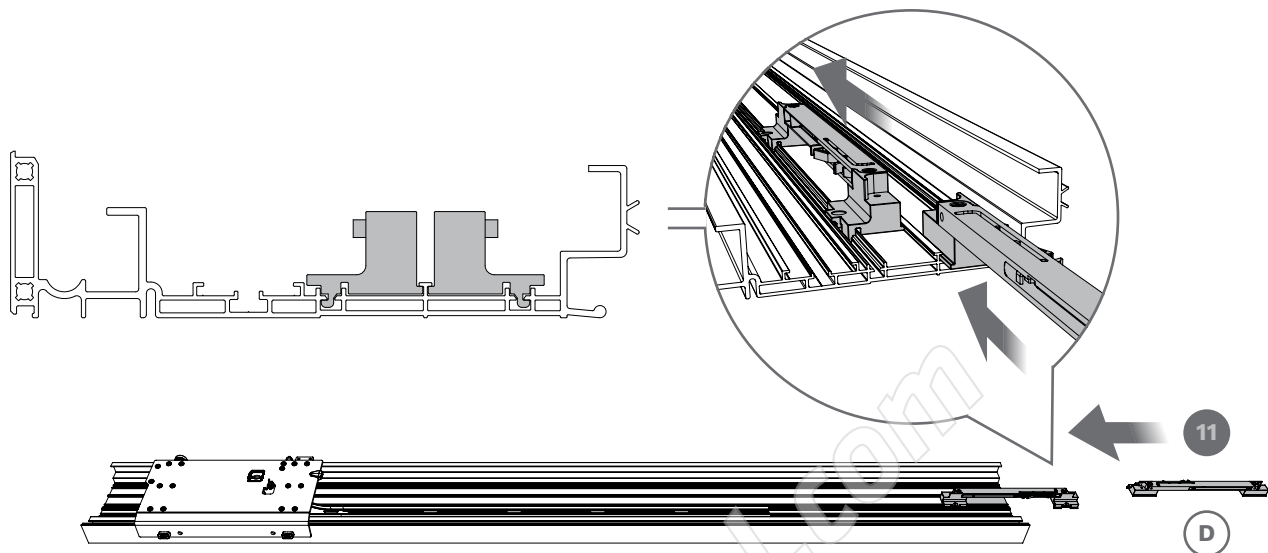

12

Y (mm)	LI (mm)	R (mm)
543	1531-1930	1705
943	1931-2330	2105
1343	2331-2730	2505
1743	2731-3200	2905

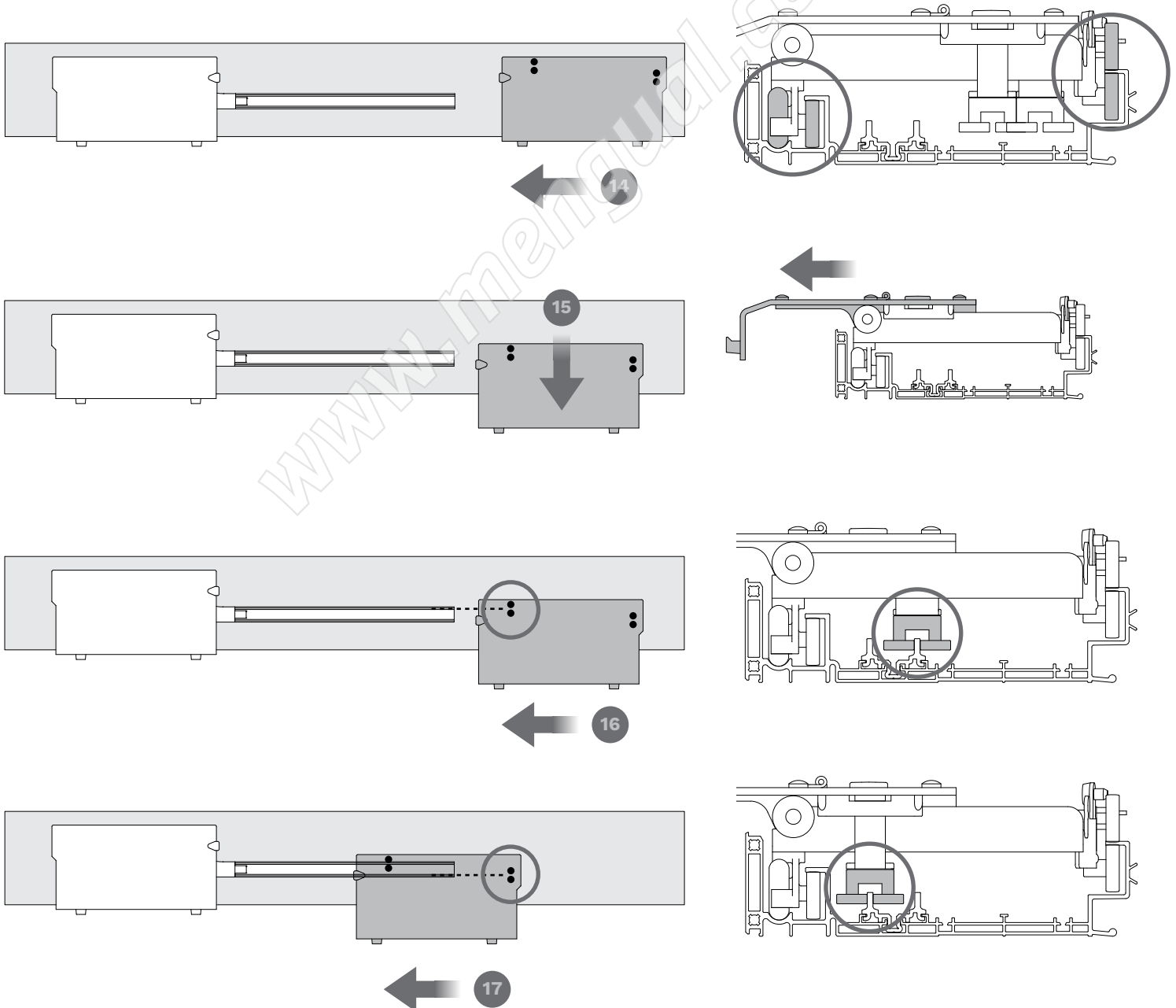
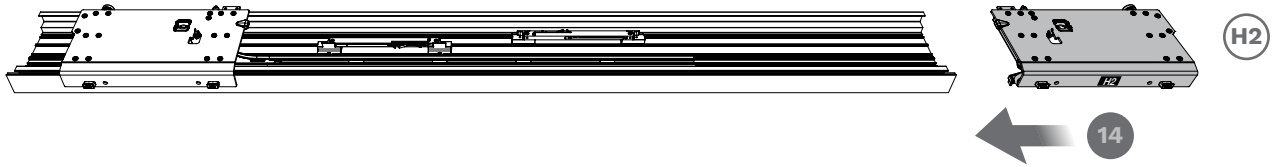
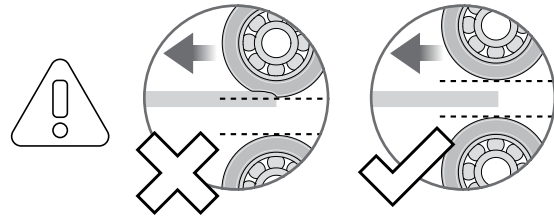

[ITA] MONTAGGIO  
DEL MECCANISMO SUPERIORE

[ENG] ASSEMBLING THE UPPER  
MECHANISM

[FRA] MONTAGE DU MÉCANISME HAUT

[ESP] MONTAJE DEL MECANISMO  
SUPERIOR

[DEU] MONTAGE DES OBEREN  
MECHANISMUS

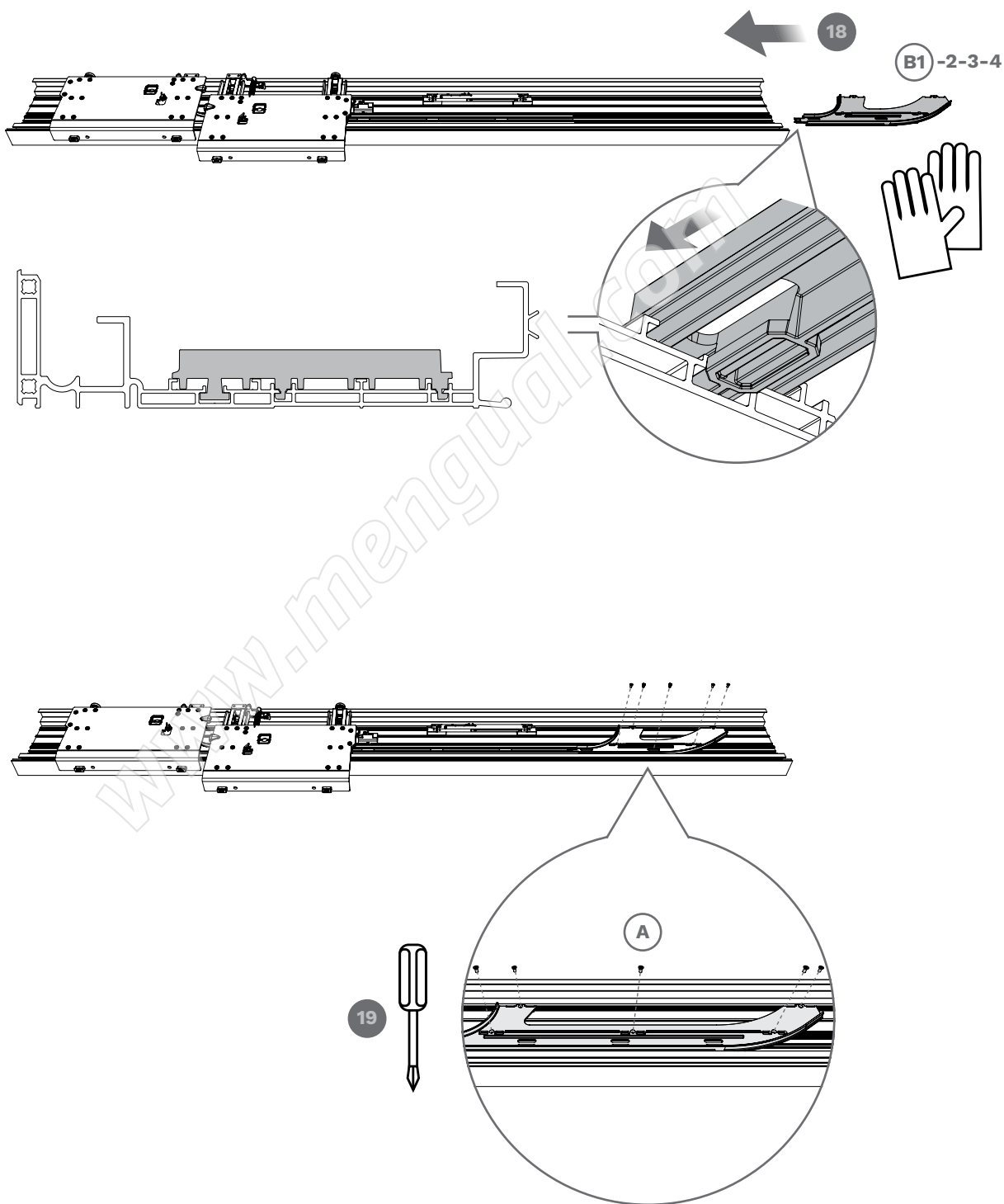

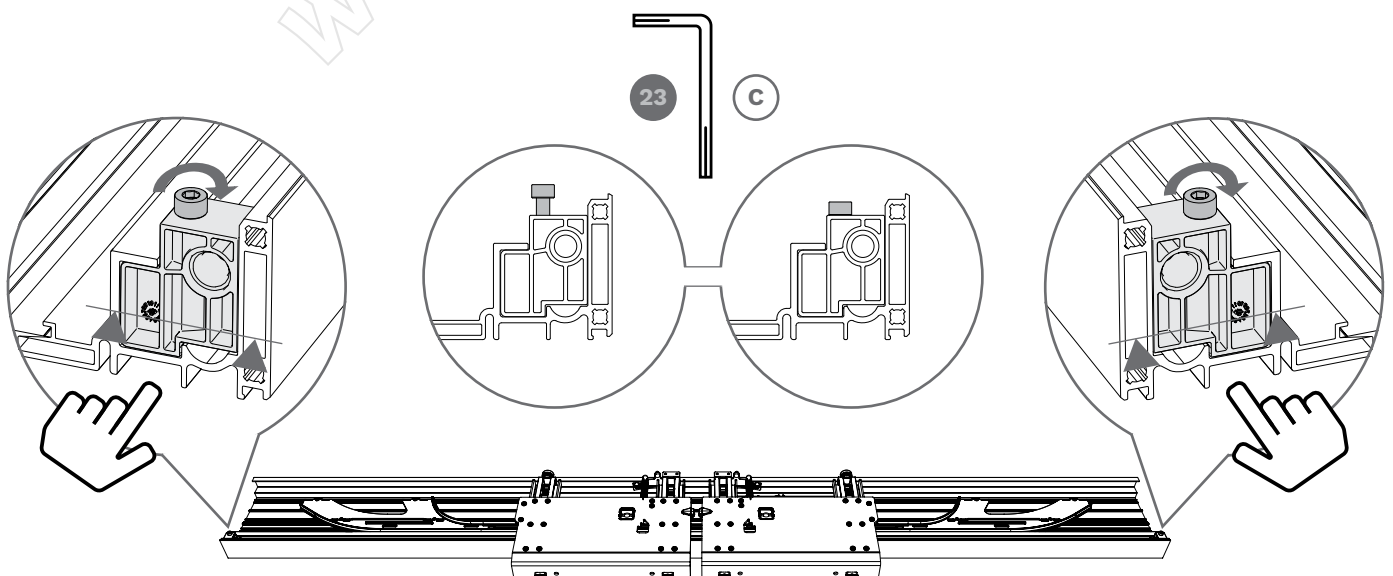
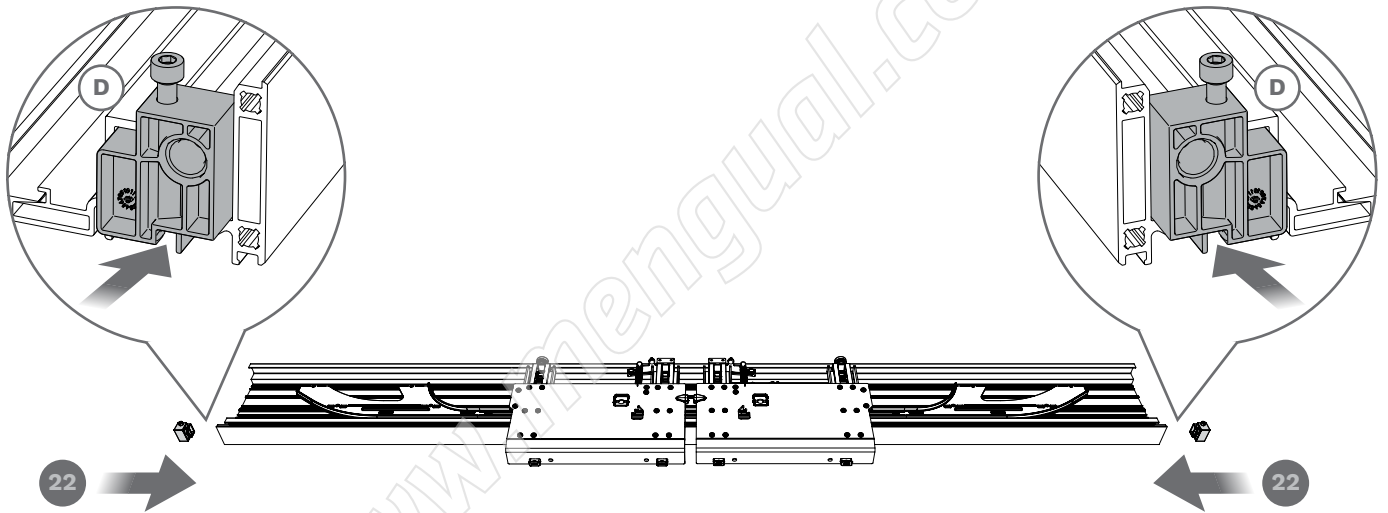
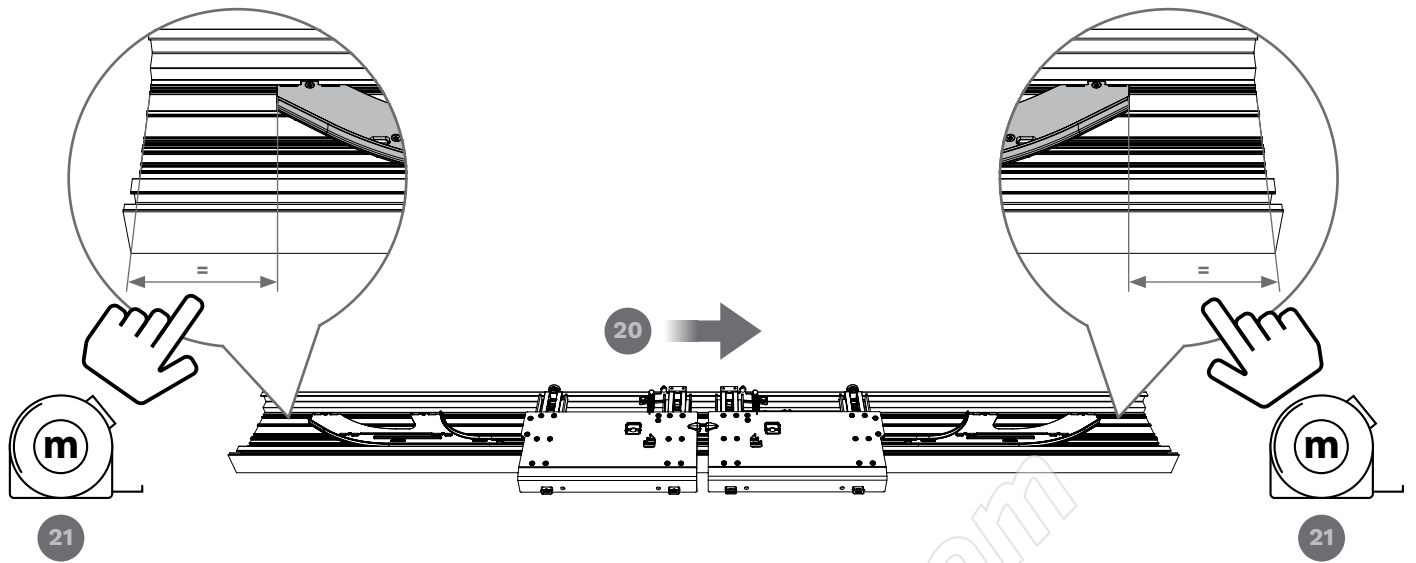

# sliderM50 FLEX

[ITA] MONTAGGIO  
DEL MECCANISMO INFERIORE

[ENG] ASSEMBLING THE LOWER  
MECHANISM

[FRA] MONTAGE DU MÉCANISME BAS

[ESP] MONTAJE DEL MECANISMO  
INFERIOR

[DEU] MONTAGE DES UNTEREN  
MECHANISMUS

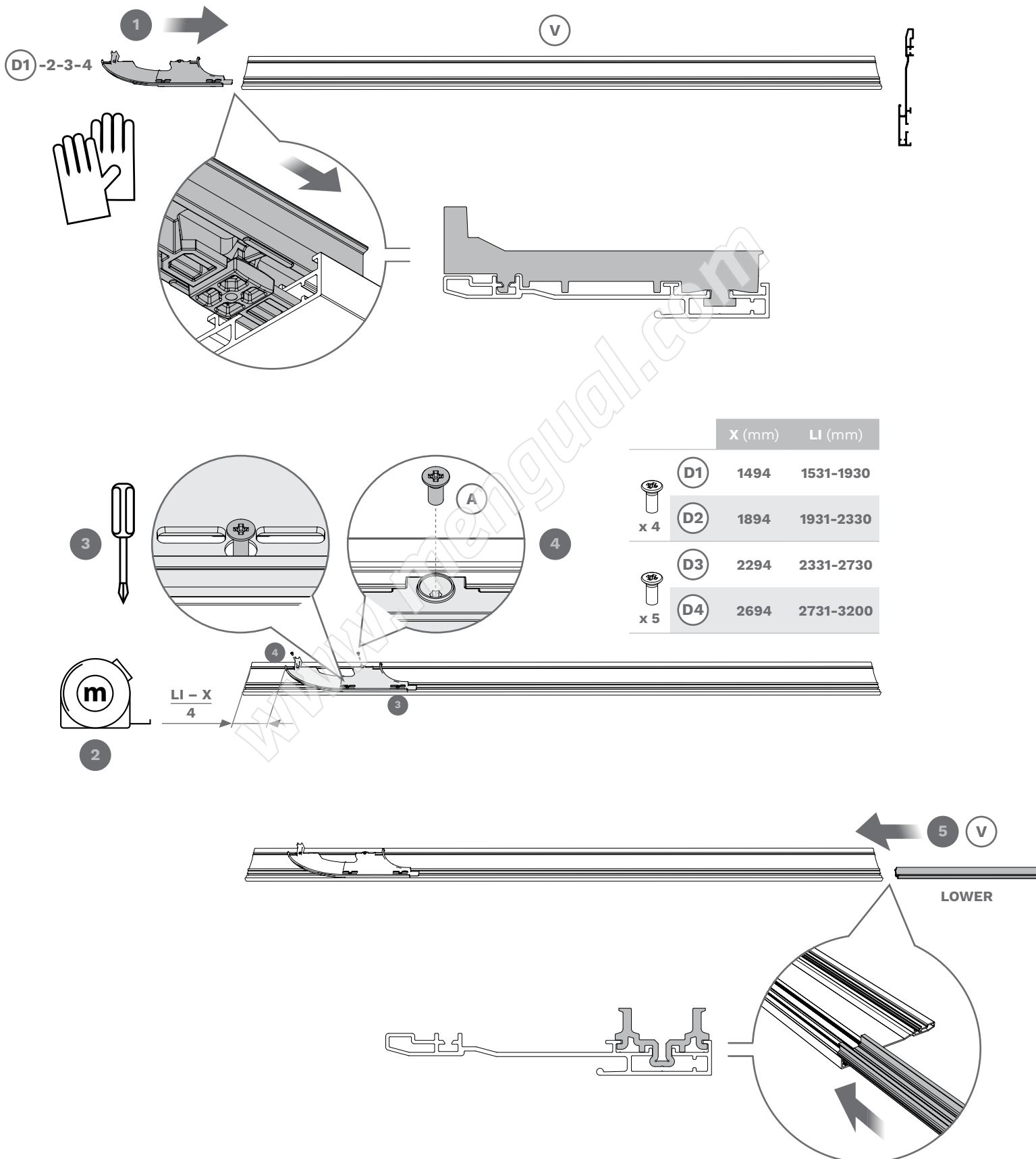

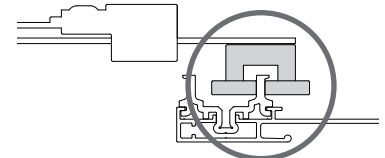
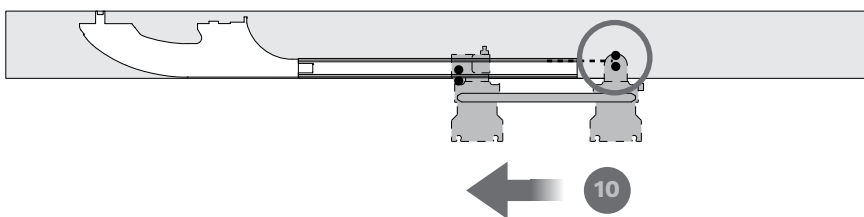
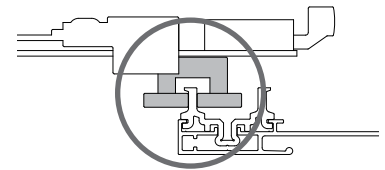
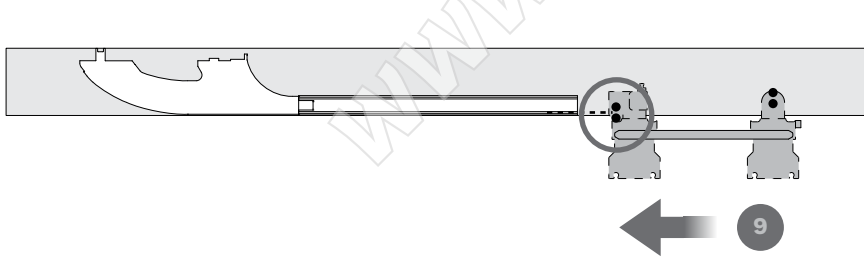
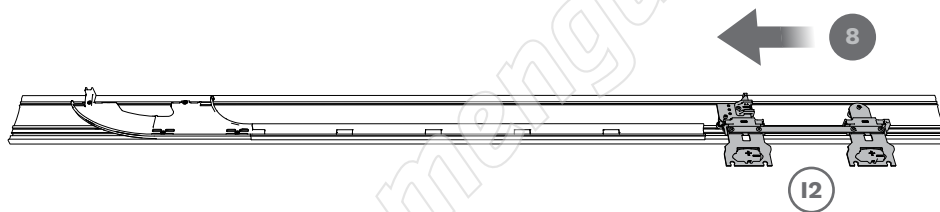
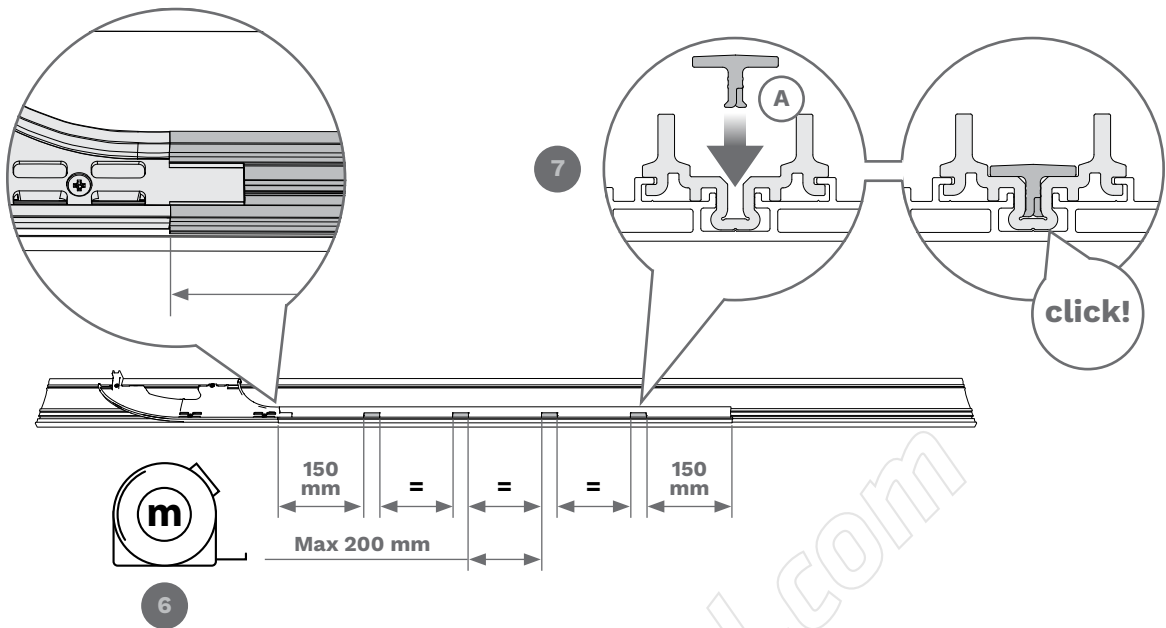

[ITA] MONTAGGIO  
DEL MECCANISMO INFERIORE

[ENG] ASSEMBLING THE LOWER  
MECHANISM

[FRA] MONTAGE DU MÉCANISME BAS

[ESP] MONTAJE DEL MECANISMO  
INFERIOR

[DEU] MONTAGE DES UNTEREN  
MECHANISMUS

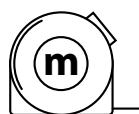
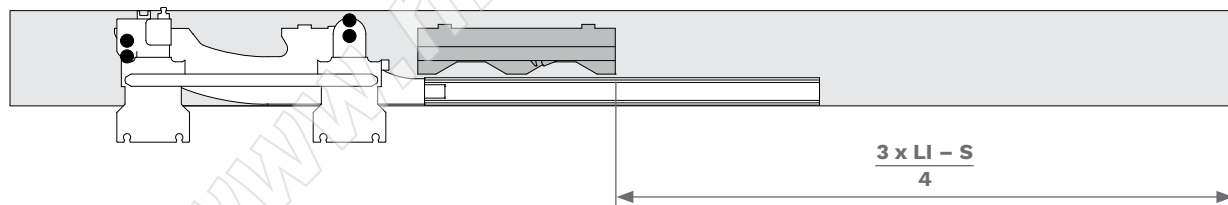
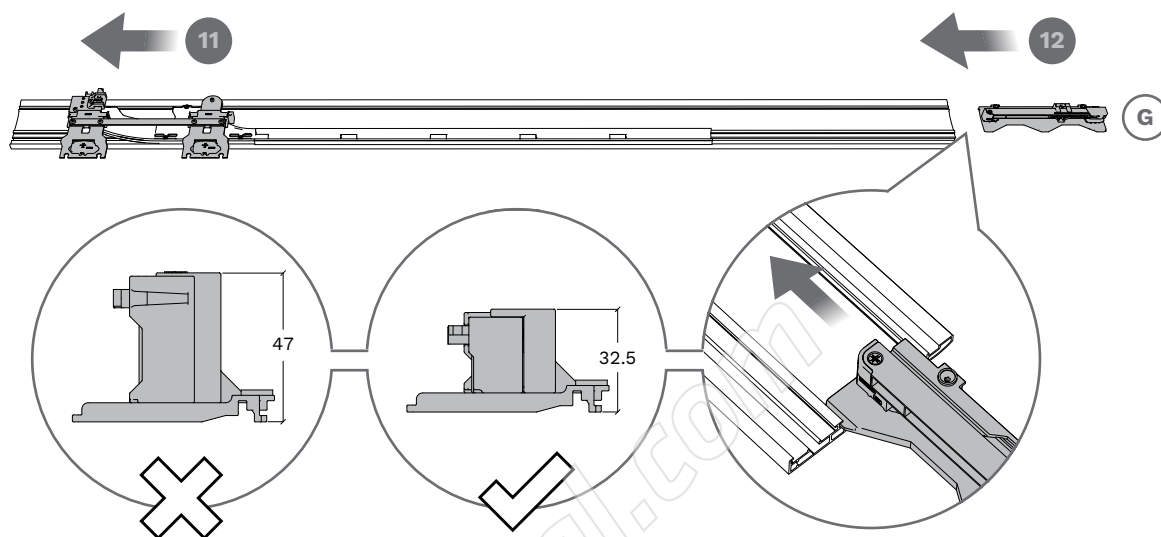

13

S (mm)	LI (mm)
1558	1531-1930
1958	1931-2330
2358	2331-2730
2758	2731-3200

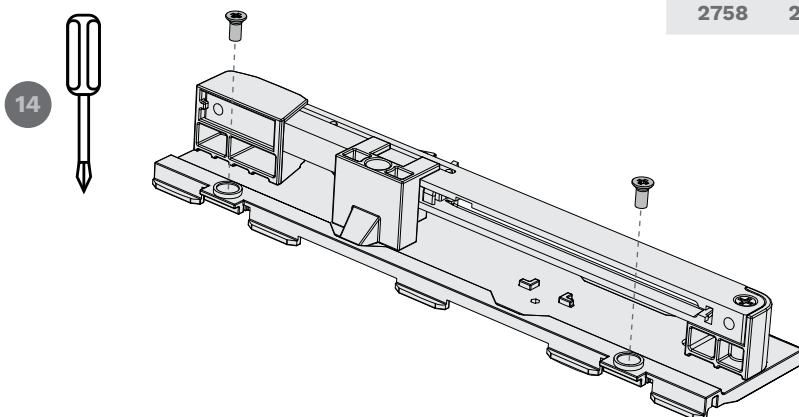

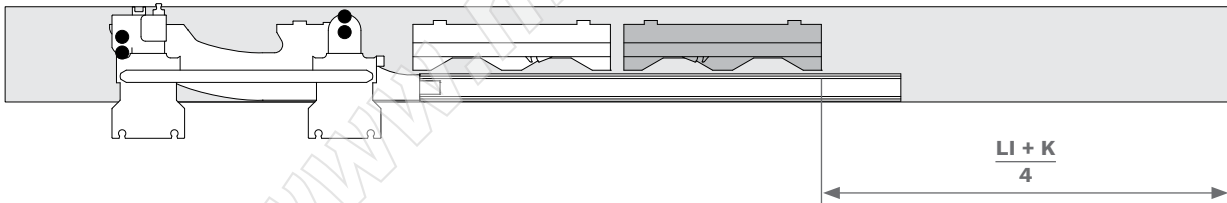
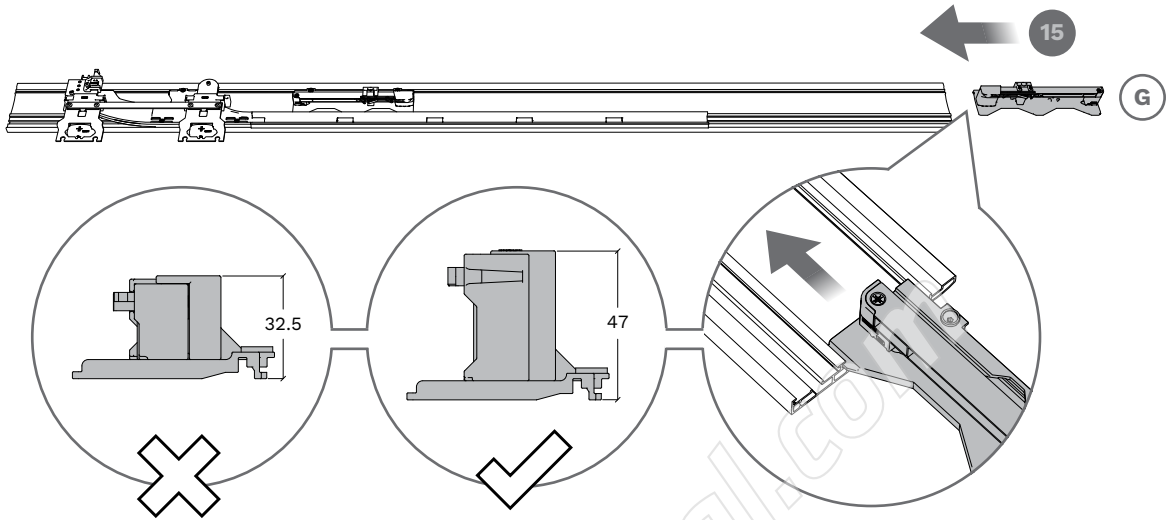

16

K (mm)	LI (mm)
342	1531-1930
742	1931-2330
1142	2331-2730
1542	2731-3200

17

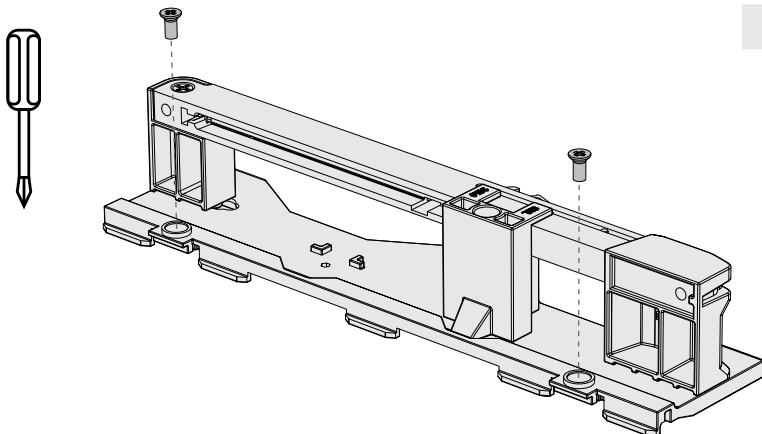

[ITA] MONTAGGIO  
DEL MECCANISMO INFERIORE

[ENG] ASSEMBLING THE LOWER  
MECHANISM

[FRA] MONTAGE DU MÉCANISME BAS

[DEU] MONTAGE DES UNTEREN  
MECHANISMUS

[ESP] MONTAJE DEL MECANISMO  
INFERIOR

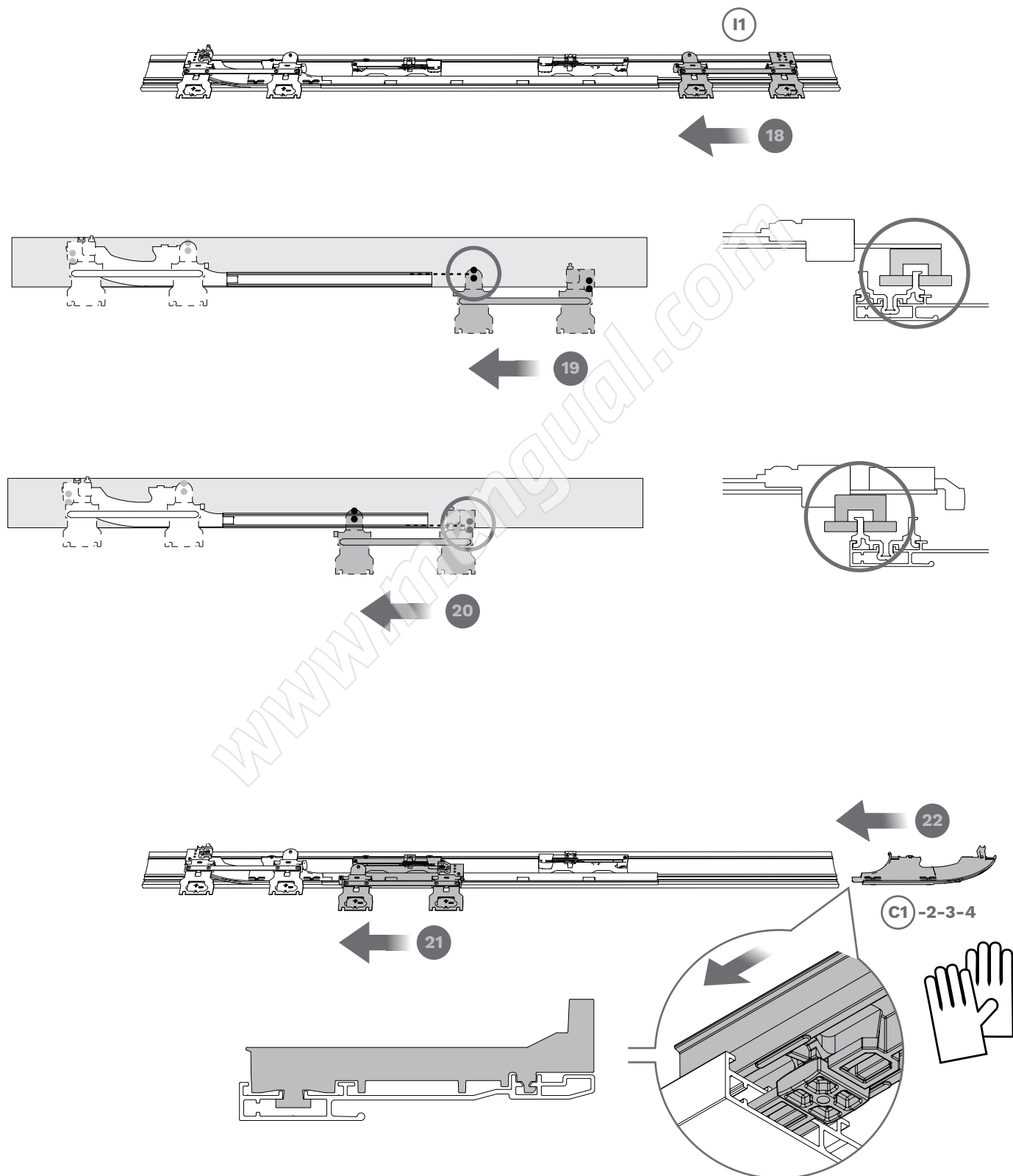

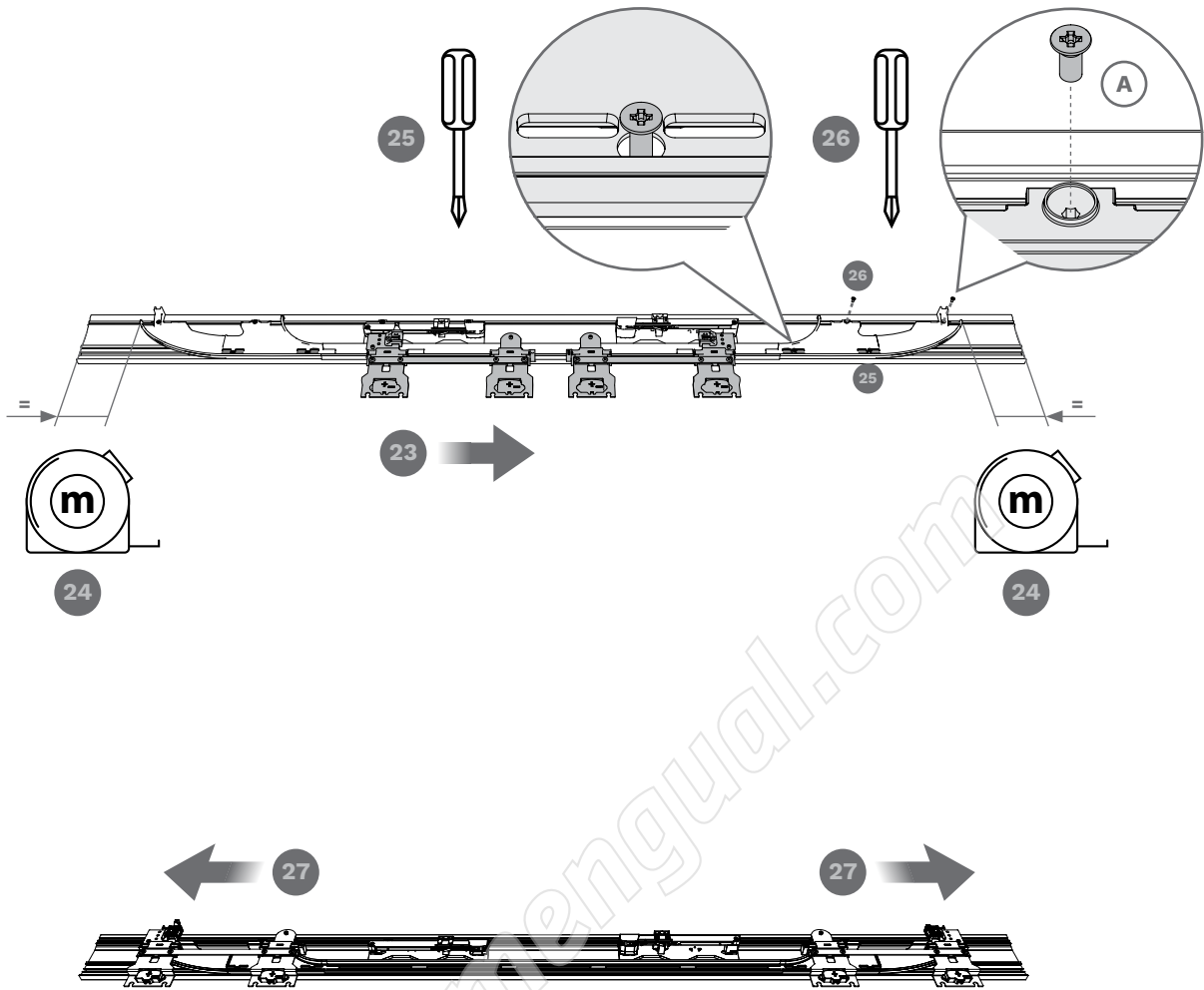

[ITA] MONTAGGIO  
DEL MECCANISMO INFERIORE

[ENG] ASSEMBLING THE LOWER  
MECHANISM

[FRA] MONTAGE DU MÉCANISME BAS

[ESP] MONTAJE DEL MECANISMO  
INFERIOR

[DEU] MONTAGE DES UNTEREN  
MECHANISMUS

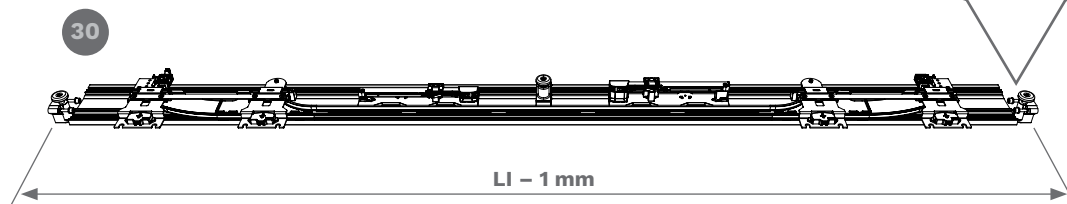
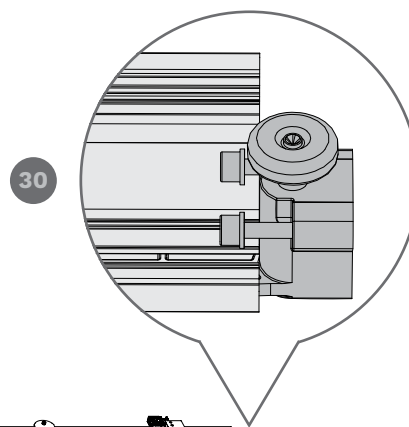
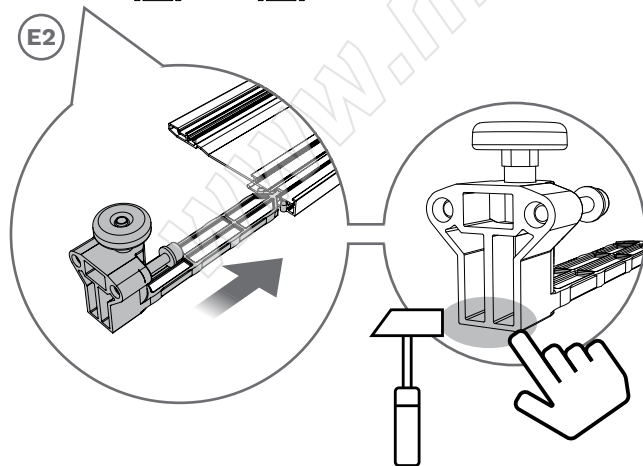
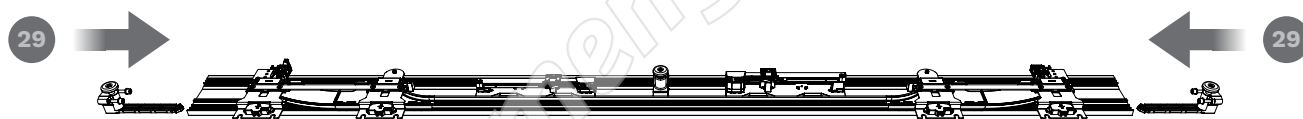
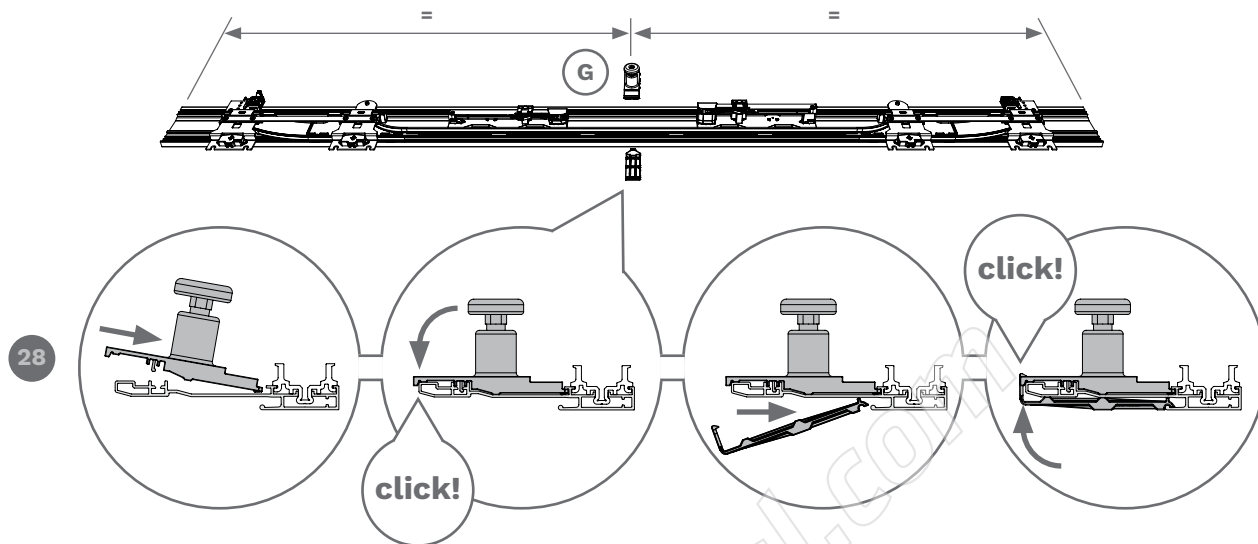

[ITA] MONTAGGIO DEL MECCANISMO INFERIORE (SENZA PIEDINI) SULLA STRUTTURA

[ENG] INSTALLING THE LOWER MECHANISM ONTO THE CABINET (WITHOUT FEET)

[FRA] MONTAGE DU MÉCANISME BAS SUR LE MEUBLE (SANS PIEDS)

[ESP] MONTAJE DEL MECANISMO INFERIOR EN LA ESTRUCTURA (SIN PIES)

[DEU] MONTAGE DES UNTEREN MECHANISMUS AM KORPUS (OHNE FÜSSE)

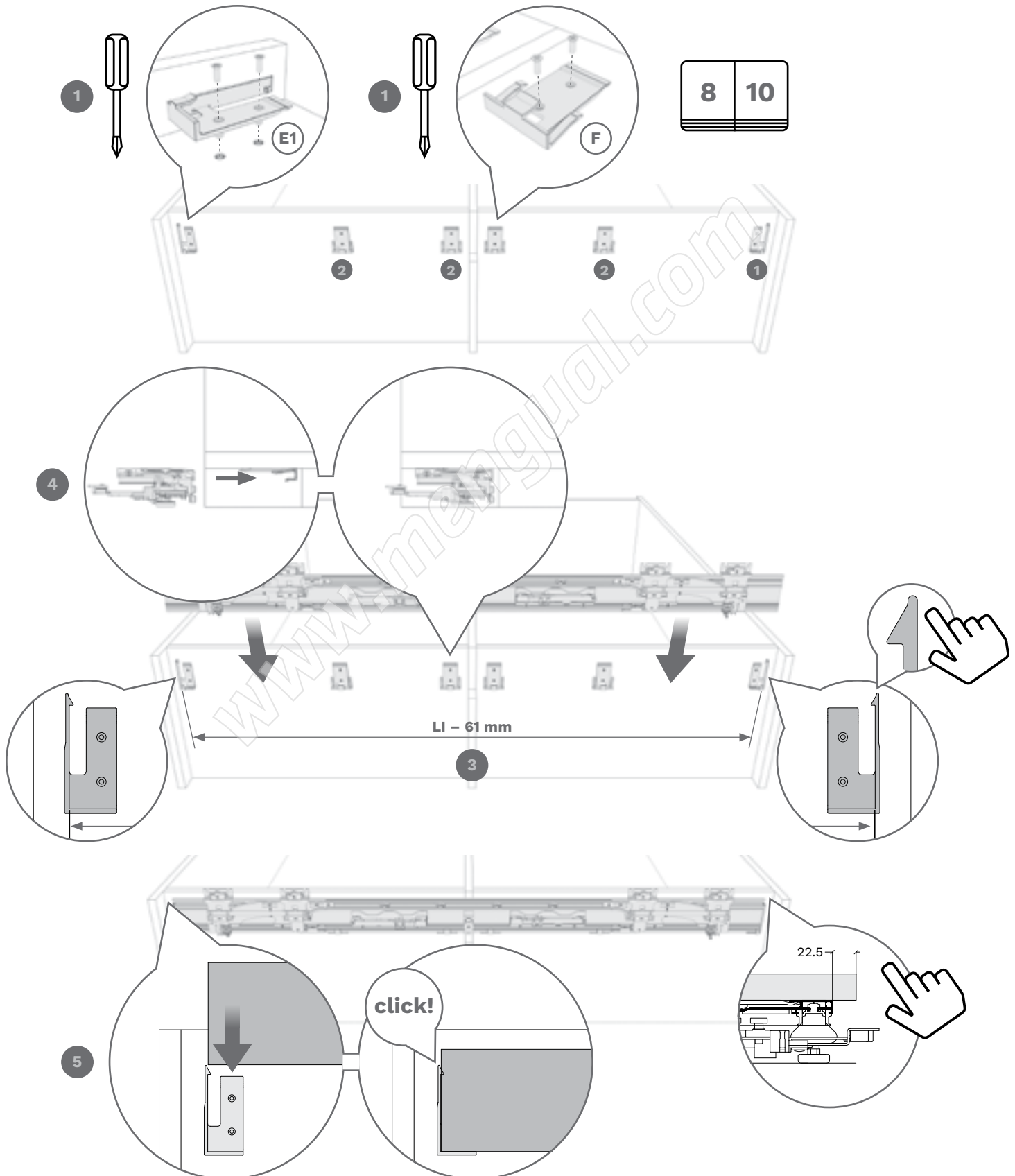

[ITA] MONTAGGIO DEL MECCANISMO INFERIORE (CON PIEDINI) SULLA STRUTTURA

[ENG] INSTALLING THE LOWER MECHANISM ONTO THE CABINET (WITH FEET)

[FRA] MONTAGE DU MÉCANISME BAS SUR LE MEUBLE (AVEC PIEDS)

[DEU] MONTAGE DES UNTEREN MECHANISMUS AM KORPUS (MIT FÜSSE)

[ESP] MONTAJE DEL MECANISMO INFERIOR EN LA ESTRUCTURA (CON PIES)

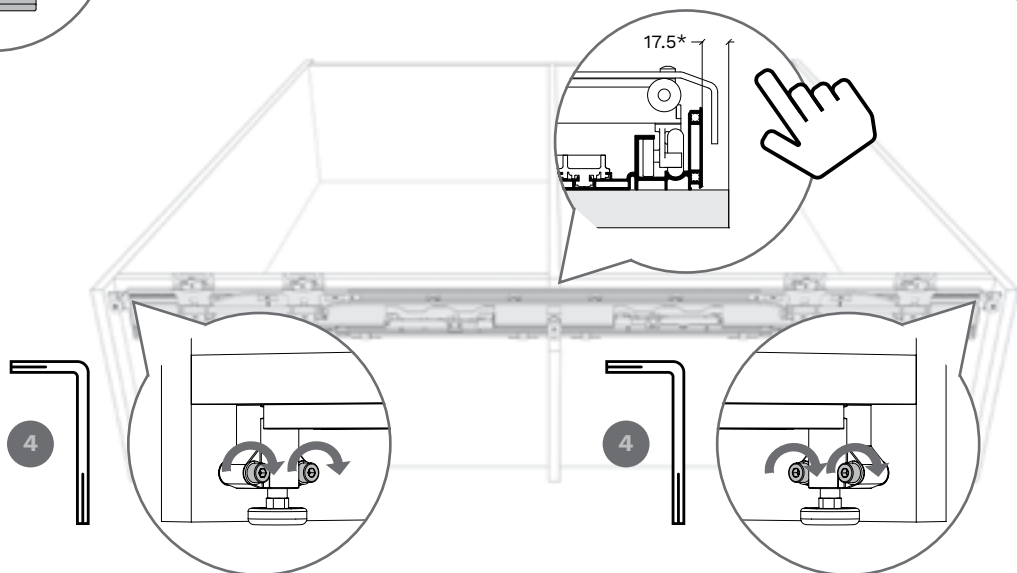
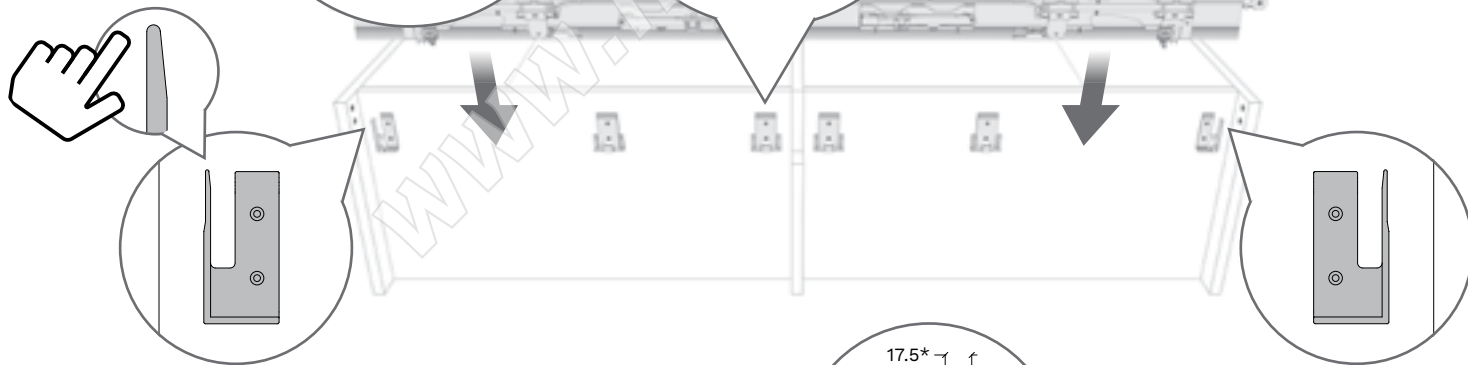
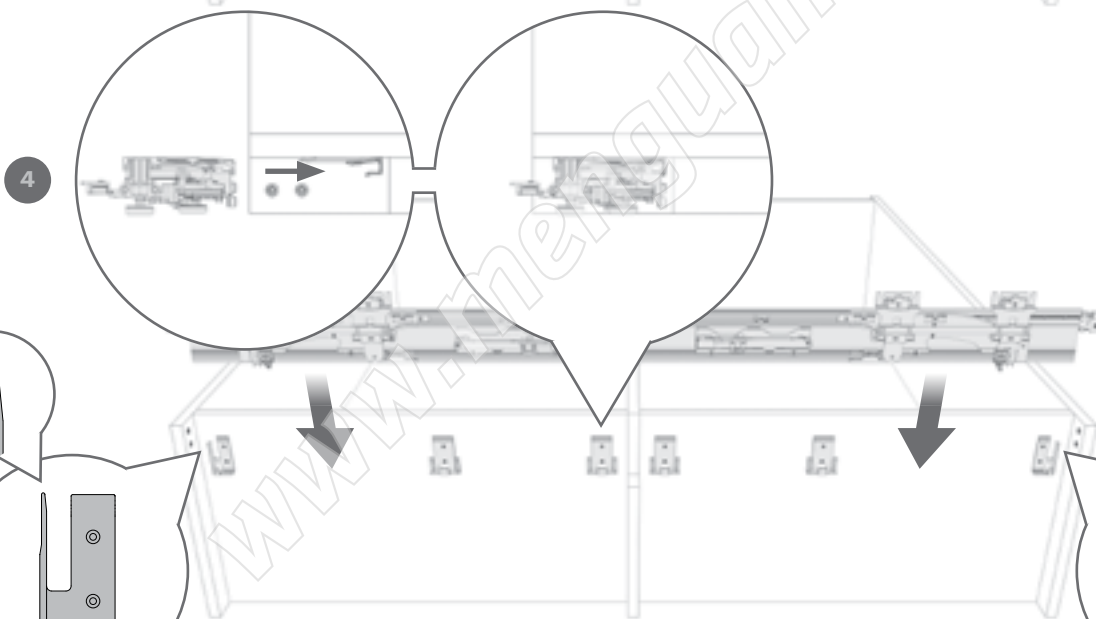
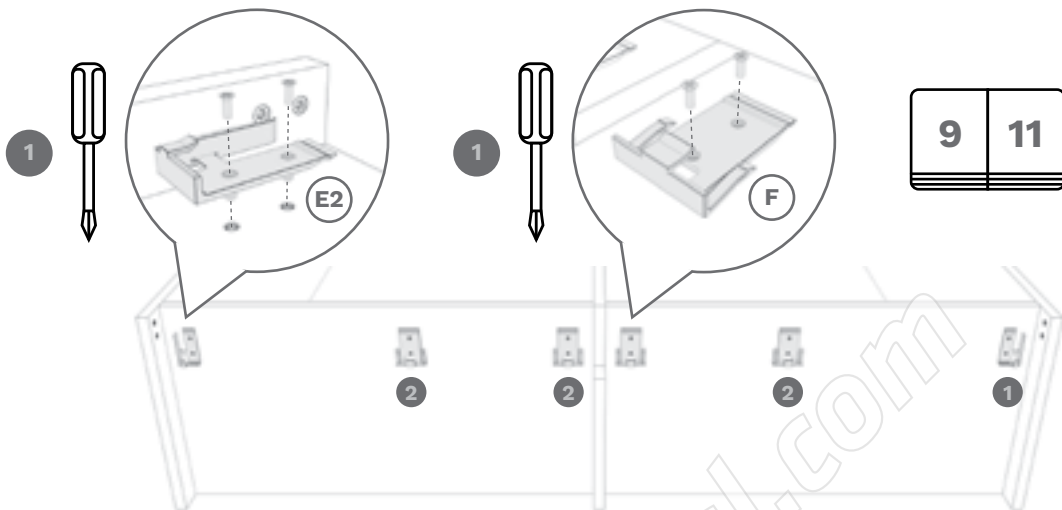

[ITA] MONTAGGIO DEL MECCANISMO SUPERIORE SULLA STRUTTURA

[ENG] INSTALLING THE UPPER MECHANISM ONTO THE CABINET

[FRA] MONTAGE DU MÉCANISME HAUT SUR LE MEUBLE

[DEU] MONTAGE DES OBEREN MECHANISMUS AM KORPUS

[ESP] MONTAJE DEL MECANISMO SUPERIOR EN LA ESTRUCTURA

8	10
9	11

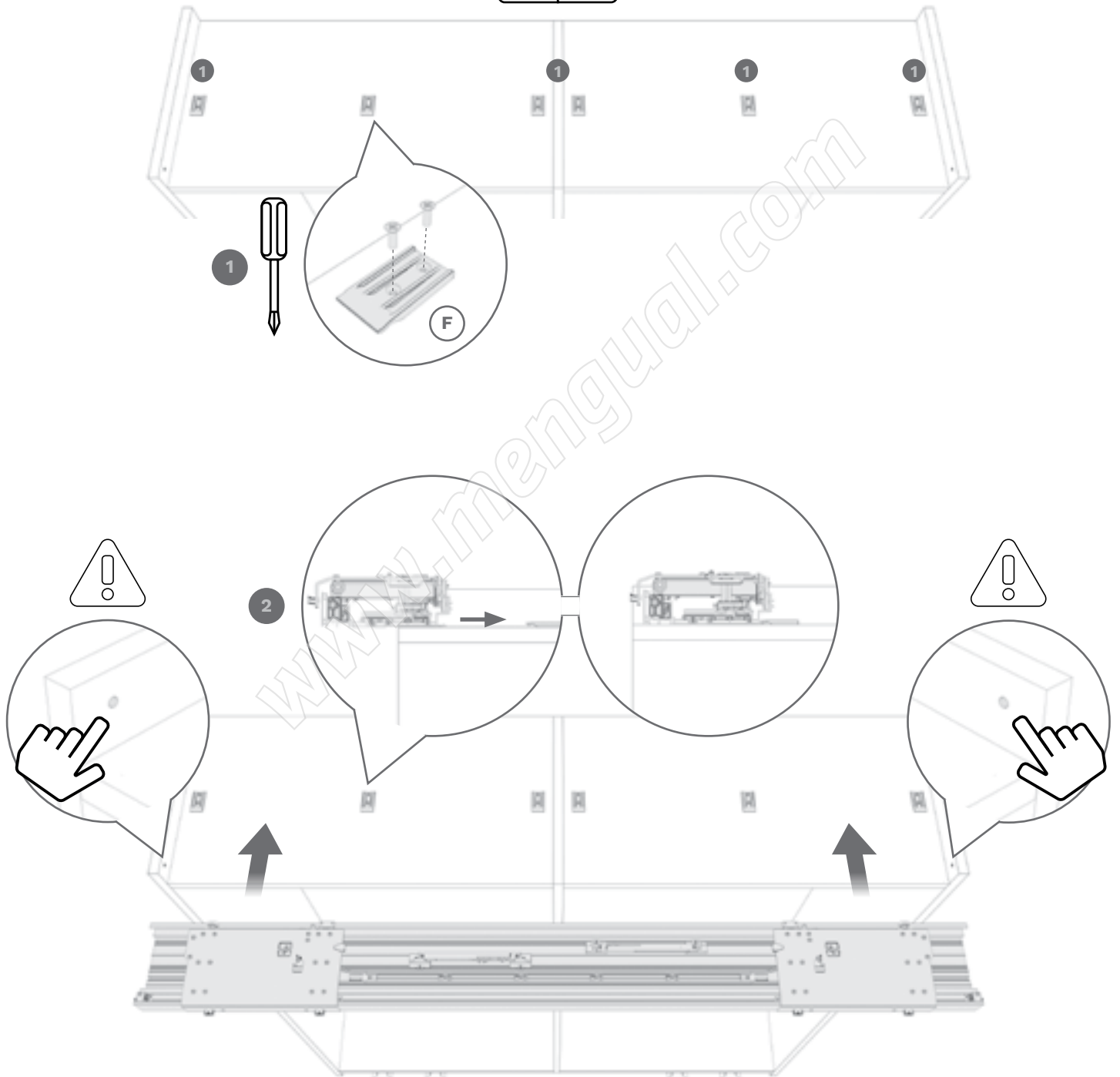

[ITA] MONTAGGIO DEL MECCANISMO SUPERIORE SULLA STRUTTURA

[ENG] INSTALLING THE UPPER MECHANISM ONTO THE CABINET

[FRA] MONTAGE DU MÉCANISME HAUT SUR LE MEUBLE

[DEU] MONTAGE DES OBEREN MECHANISMUS AM KORPUS

[ESP] MONTAJE DEL MECANISMO SUPERIOR EN LA ESTRUCTURA

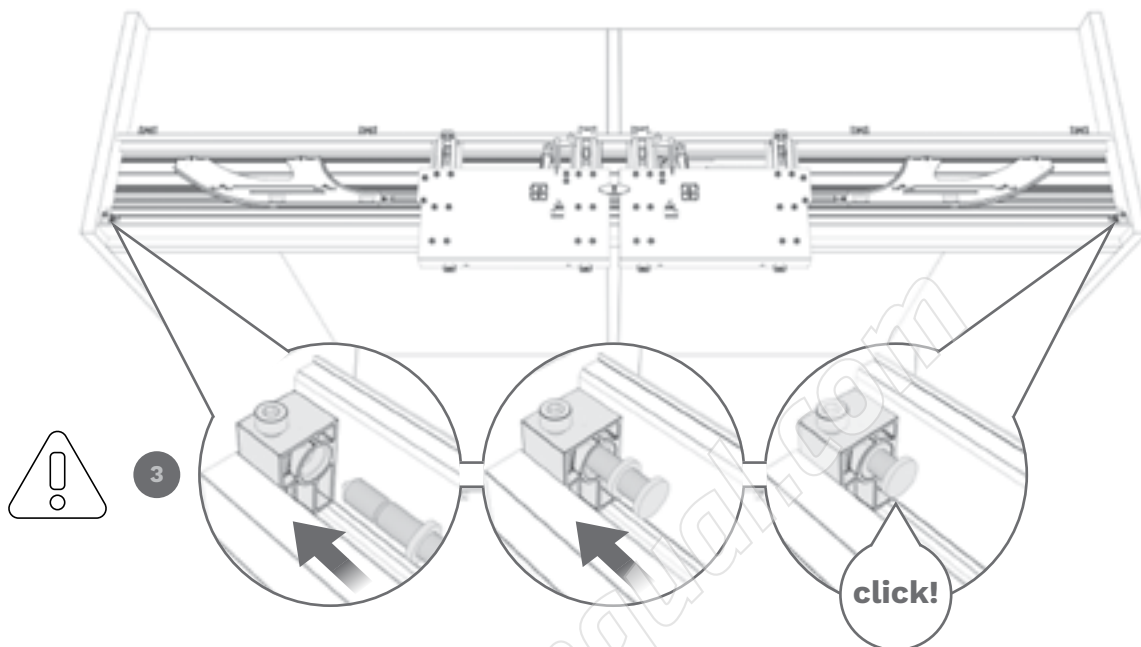

- \* Con telaio Clipper (-5 mm)
- \* With Clipper frame (-5 mm)
- \* Mit Clipper Beschläger (-5 mm)
- \* Avec cadre Clipper (-5 mm)
- \* Con bastodor Clipper (-5 mm)

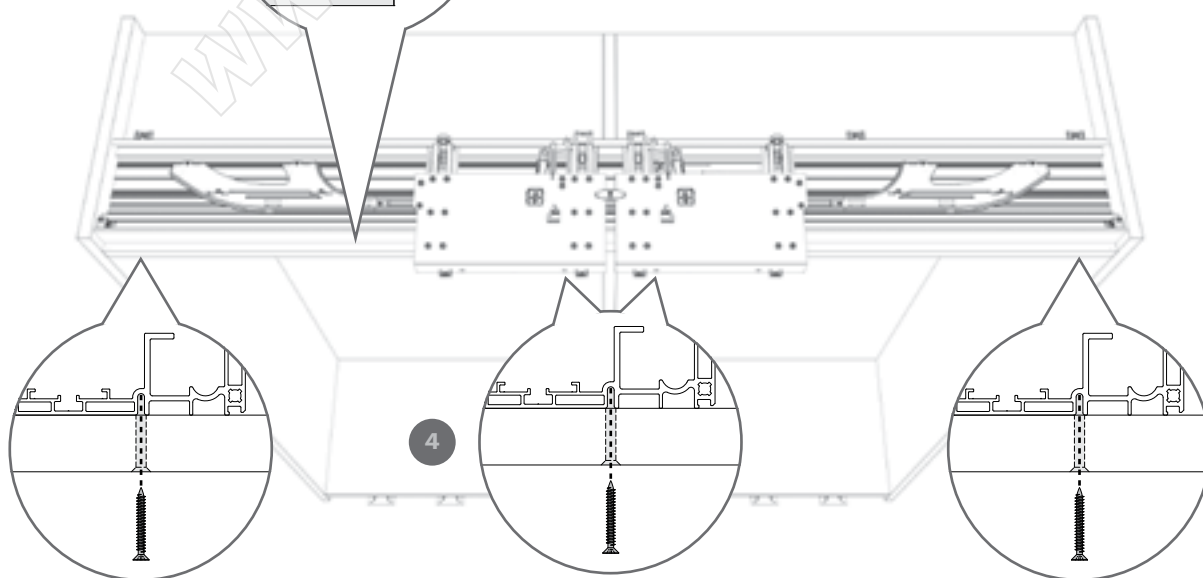
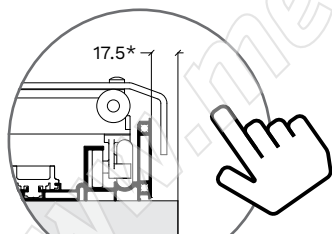

[ITA] **PREPARAZIONE DELL'ANTA DESTRA**

[ENG] **PREPARATION OF THE RIGHT DOOR**

[FRA] **PRÉPARATION DE LA PORTE DROITE**

[DEU] **VORBEREITUNG DES RECHTEN TÜRFLÜGELS**

[ESP] **PREPARACIÓN DE LA PUERTA DERECHA**

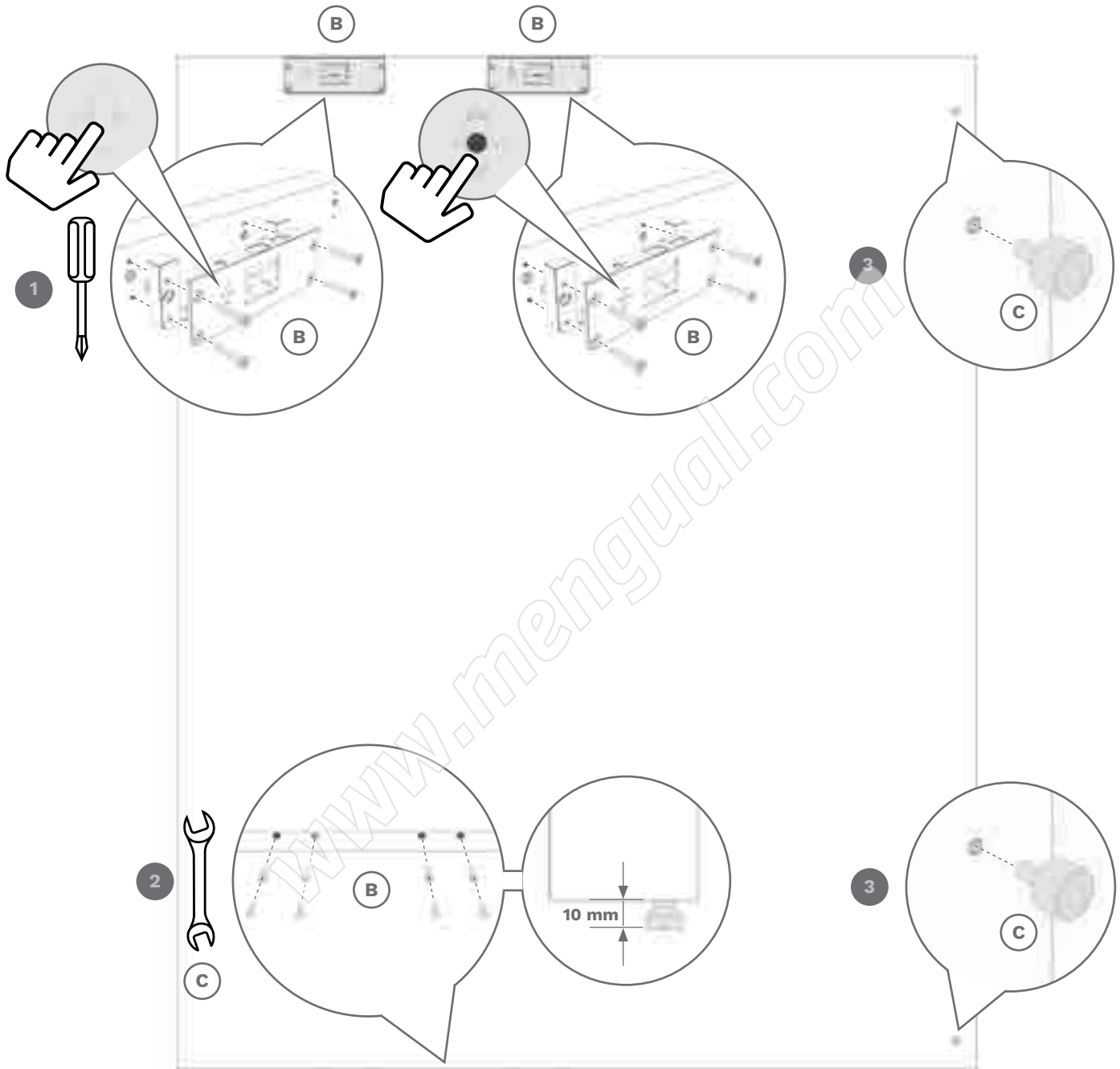

[ITA] **PREPARAZIONE DELL'ANTA SINISTRA**

Ripetere la sequenza delle operazioni da **1** a **3**.

[ENG] **PREPARATION OF THE LEFT DOOR**

Repeat the steps from **1** to **3**.

[DEU] **VORBEREITUNG DES LINKEN TÜRFLÜGELS**

Die Abfolge der Tätigkeiten von **1** bis **3** wiederholen.

[FRA] **PRÉPARATION DE LA PORTE GAUCHE**

Répéter les étapes des opérations de **1** à **3**.

[ESP] **PREPARACIÓN DE LA PUERTA IZQUIERDA**

Repetir la secuencia de las operaciones desde la **1** has la **3**.

[ITA] MESSA IN BOLLA DEL MOBILE

[ENG] UNIT LEVELLING

[FRA] MISE À NIVEAU DU MEUBLE

[DEU] MÖBEL AUSRICHTEN

[ESP] NIVELACIÓN DEL MUEBLE



[ITA] MONTAGGIO DELL'ANTA DESTRA

[ENG] MOUNTING THE RIGHT DOOR

[FRA] MONTAGE DE LA PORTE DROITE

[DEU] MONTAGE DES RECHTEN TÜRFLÜGELS

[ESP] MONTAJE DE LA PUERTA DERECHA

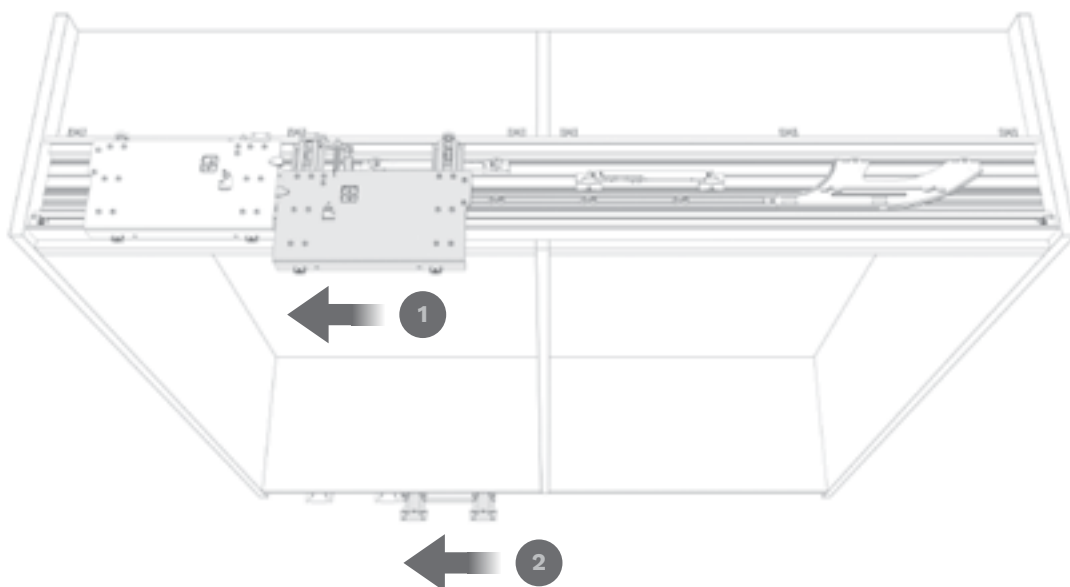

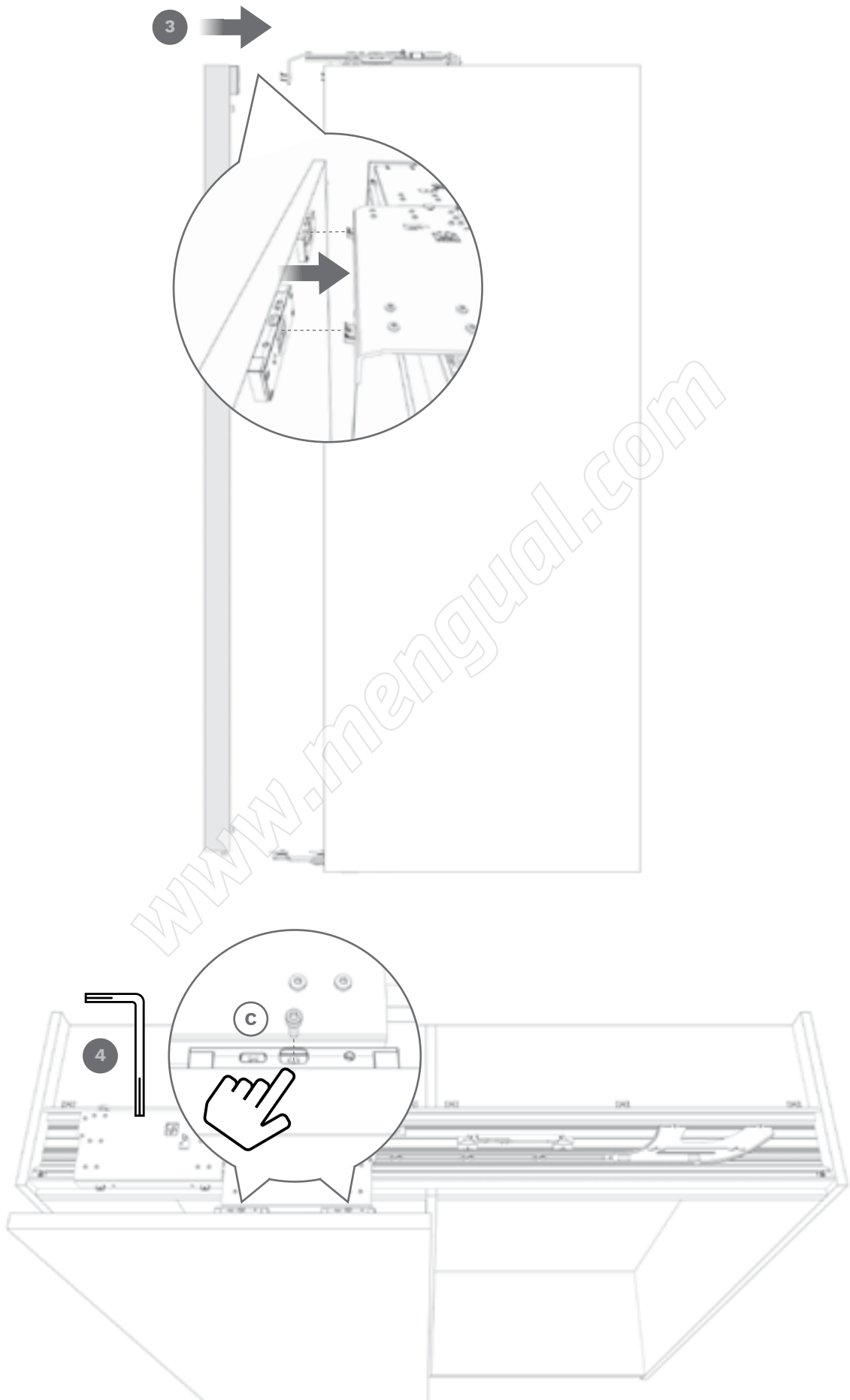

[ITA] MONTAGGIO DELL'ANTA DESTRA

[ENG] MOUNTING THE RIGHT DOOR

[FRA] MONTAGE DE LA PORTE DROITE

[DEU] MONTAGE DES RECHTEN  
TÜRFLÜGELS

[ESP] MONTAJE DE LA PUERTA DERECHA

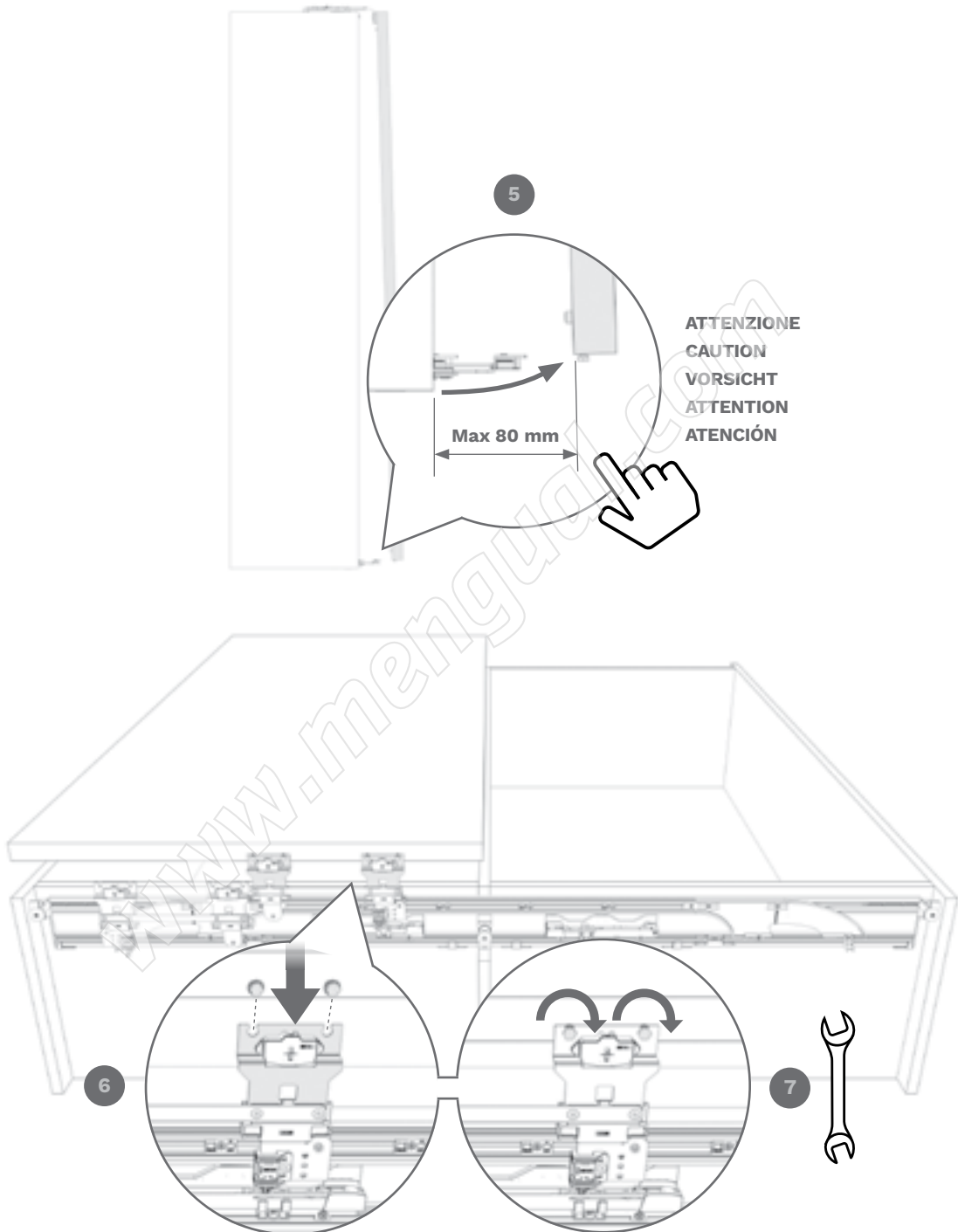

[ITA] MONTAGGIO DELL'ANTA SINISTRA

Ripetere la sequenza delle operazioni da  
1 a 7.

[ENG] MOUNTING THE LEFT DOOR

Repeat the steps from 1 to 7.

[FRA] MONTAGE DE LA PORTE GAUCHE

Répéter les étapes des opérations de 1  
à 7.

[DEU] MONTAGE DES LINKEN  
TÜRFLÜGELS

Die Abfolge der Tätigkeiten von 1 bis 7  
wiederholen.

[ESP] MONTAJE DE LA PUERTA  
IZQUIERDA

Repetir la secuencia de las operaciones  
desde la 1 has la 7.

[ITA] REGOLAZIONE DEL PARALLELISMO  
E REGOLAZIONE VERTICALE DELL'ANTA

[ENG] HORIZONTAL ADJUSTMENT AND  
VERTICAL ADJUSTMENT OF THE DOOR

[FRA] RÉGLAGE DU PARALLÉLISME ET  
RÉGLAGE VERTICAL DE LA PORTE

[DEU] PARALLELE AUSRICHTUNG UND  
VERTIKALE EINSTELLUNG DER TÜR

[ESP] REGULACIÓN DEL PARALELISMO Y  
REGULACIÓN VERTICAL DE LA PUERTA

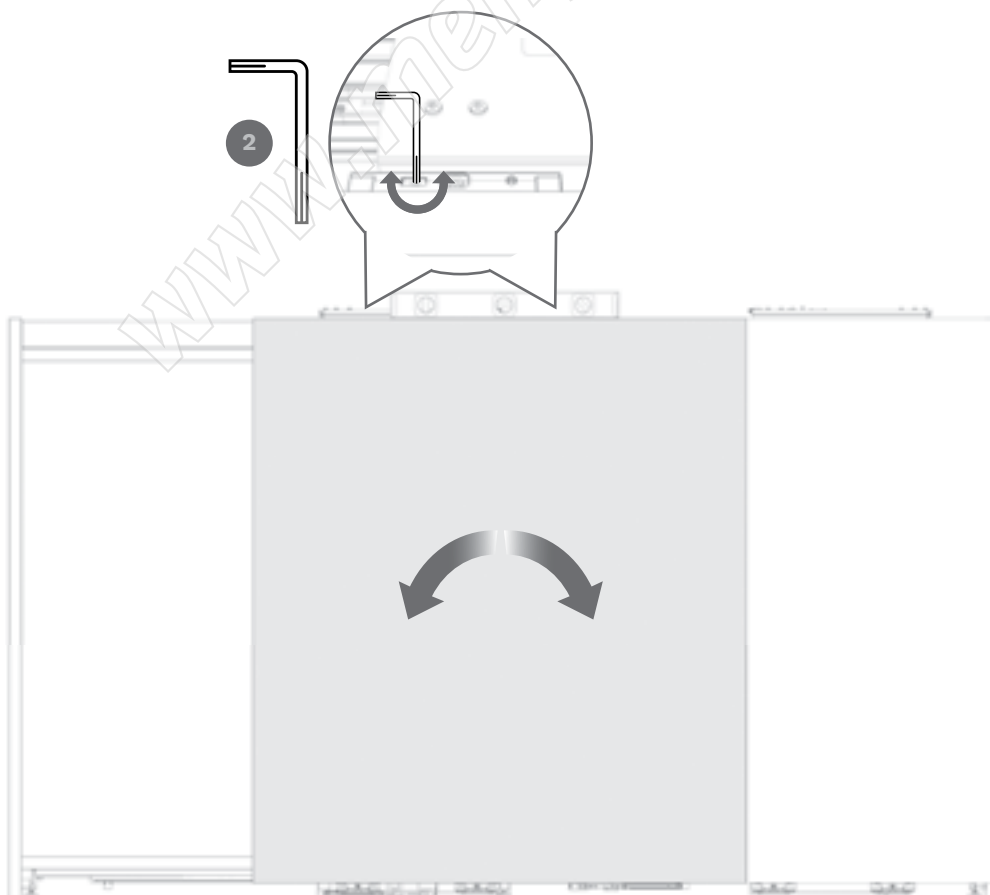
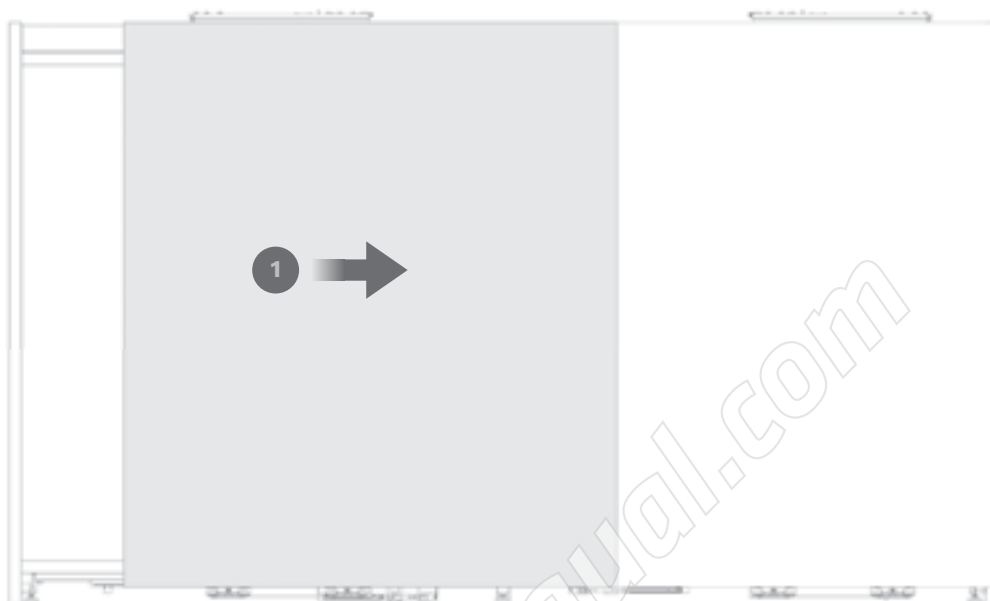

[ITA] REGOLAZIONE DEL PARALLELISMO  
E REGOLAZIONE VERTICALE DELL'ANTA

[ENG] HORIZONTAL ADJUSTMENT AND  
VERTICAL ADJUSTMENT OF THE DOOR

[FRA] RÉGLAGE DU PARALLÉLISME ET  
RÉGLAGE VERTICAL DE LA PORTE

[DEU] PARALLELE AUSRICHTUNG UND  
VERTIKALE EINSTELLUNG DER TÜR

[ESP] REGULACIÓN DEL PARALELISMO Y  
REGULACIÓN VERTICAL DE LA PUERTA

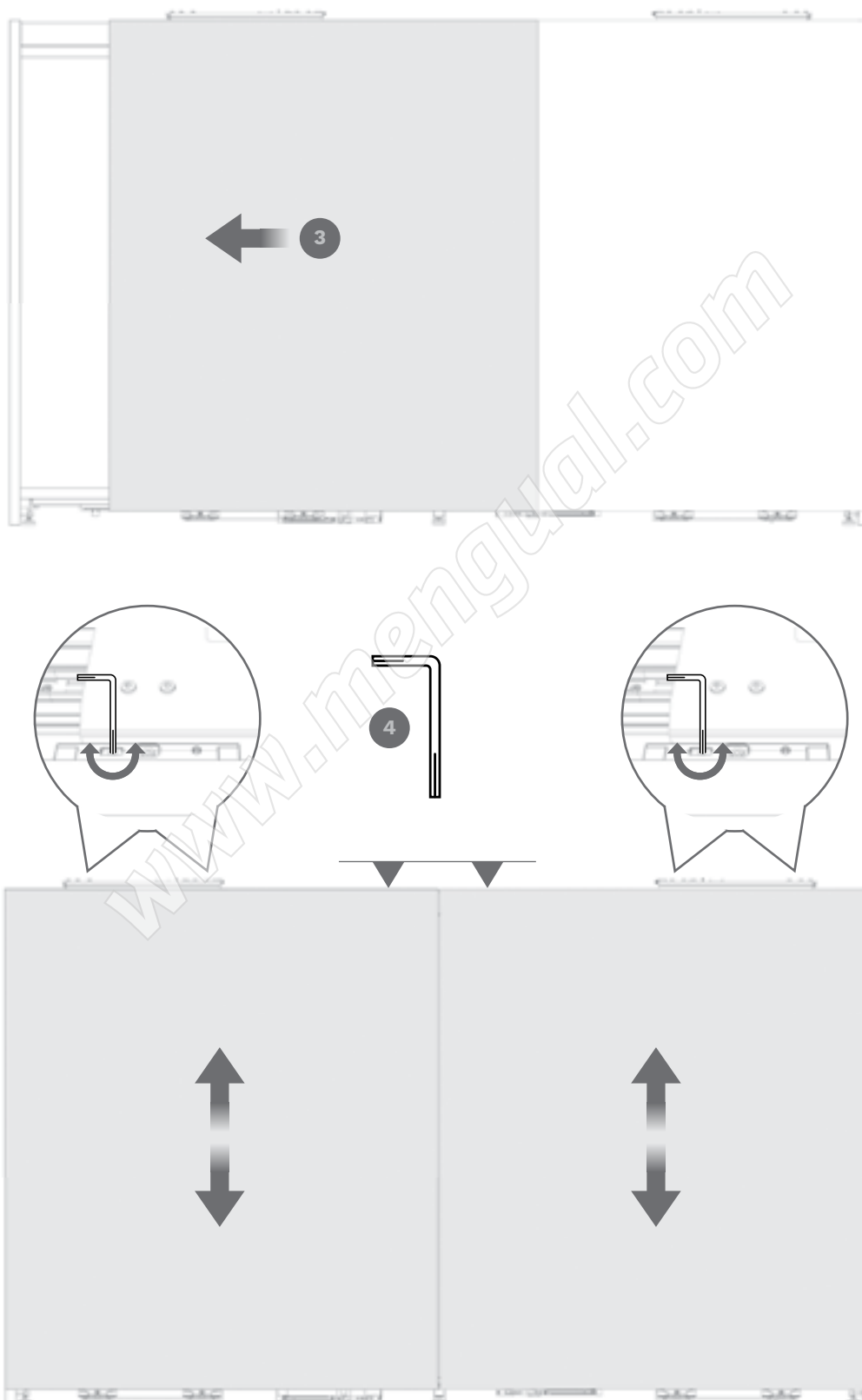

[ITA] REGOLAZIONE ORIZZONTALE DELL'ANTA

[ENG] HORIZONTAL ADJUSTMENT OF THE DOOR

[FRA] RÉGLAGE HORIZONTAL DE LA PORTE

[DEU] HORIZONTALE EINSTELLUNG DER TÜR

[ESP] REGULACIÓN HORIZONTAL DE LA PUERTA

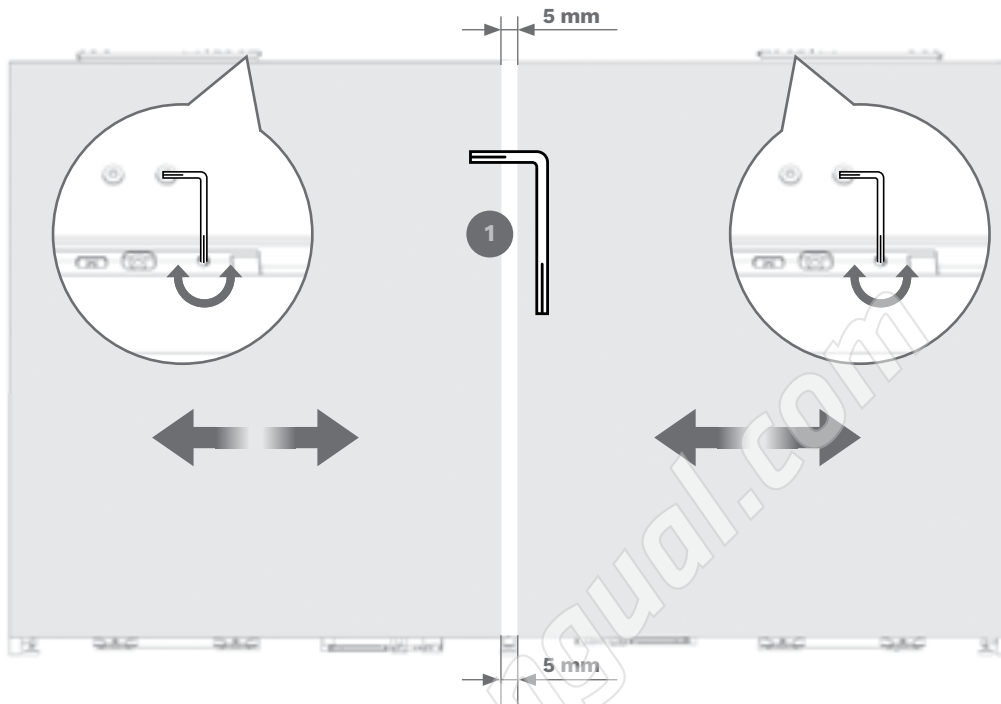

[ITA] REGOLAZIONE FRONTALE: SUPERIORE ED INFERIORE

[ENG] FRONT ADJUSTMENT: TOP AND BOTTOM

[FRA] RÉGLAGE FRONTAL : SUPÉRIEUR ET INFÉRIEUR

[DEU] FRONTALE REGULIERUNG: OBEN UND UNTEN

[ESP] REGULACIÓN FRONTAL: SUPERIOR E INFERIOR

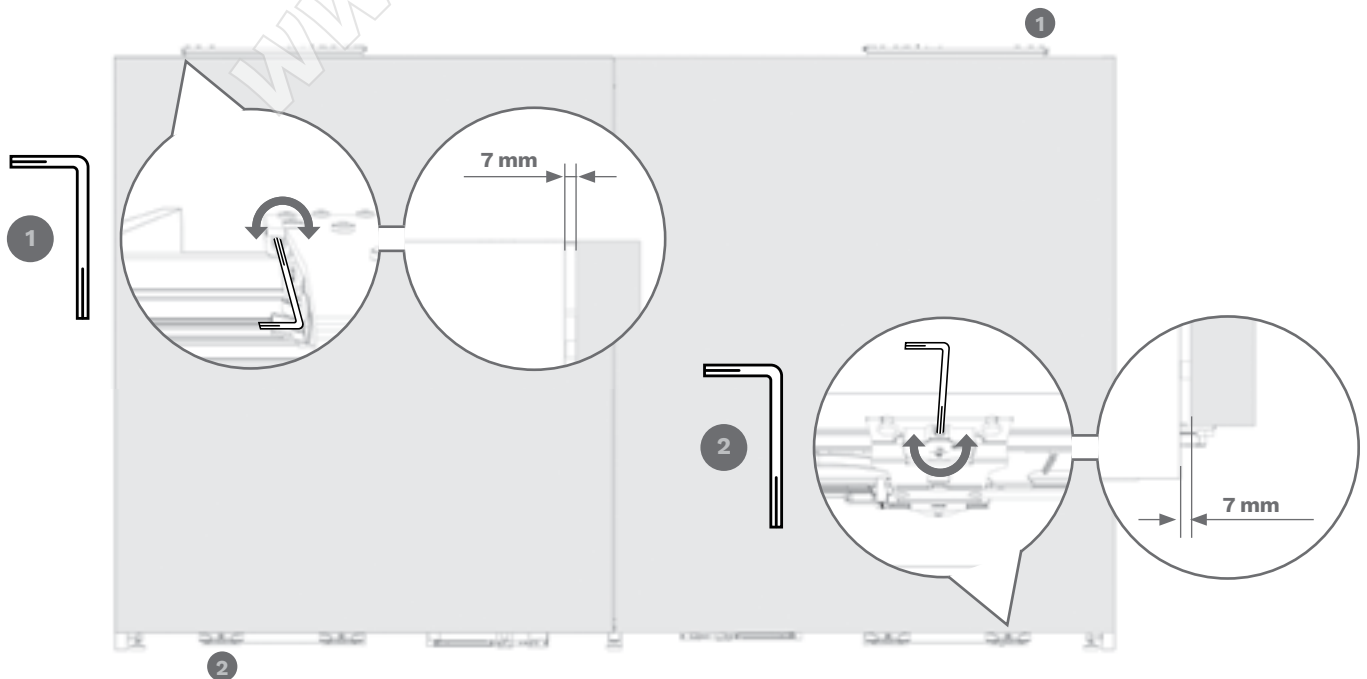

[ITA] REGOLAZIONE DELLA VELOCITÀ  
DI CHIUSURA DELL'ANTA

[ENG] ADJUSTMENT OF THE CLOSING  
SPEED OF THE DOOR

[FRA] RÉGLAGE DE LA VITESSE DE  
FERMETURE DE LA PORTE

[DEU] VERSTELLUNG DER  
SCHLISSGESCHWINDIGKEIT DER TÜR

[ESP] REGULACIÓN DE LA VELOCIDAD DE  
CIERRE DE LA PUERTA

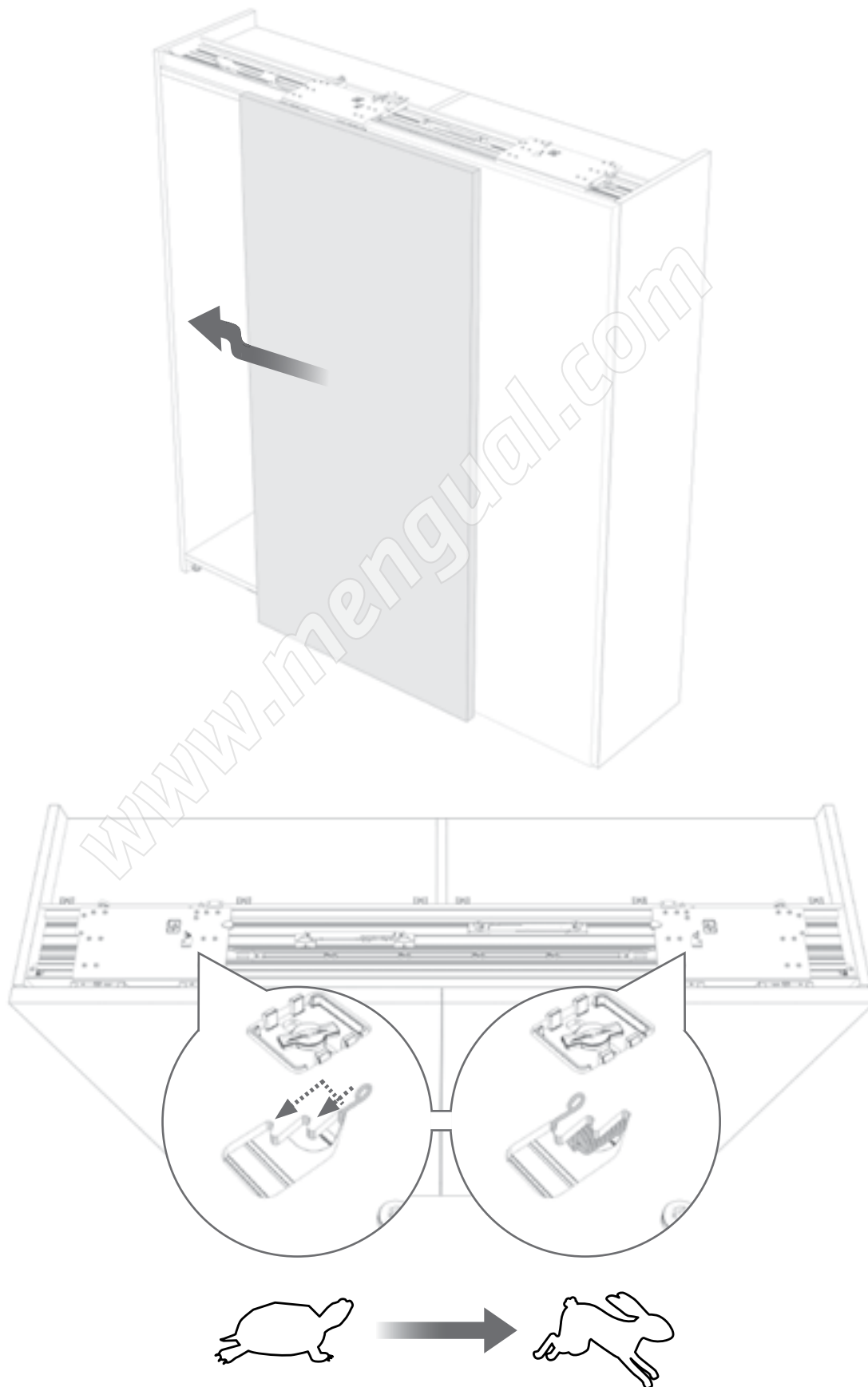

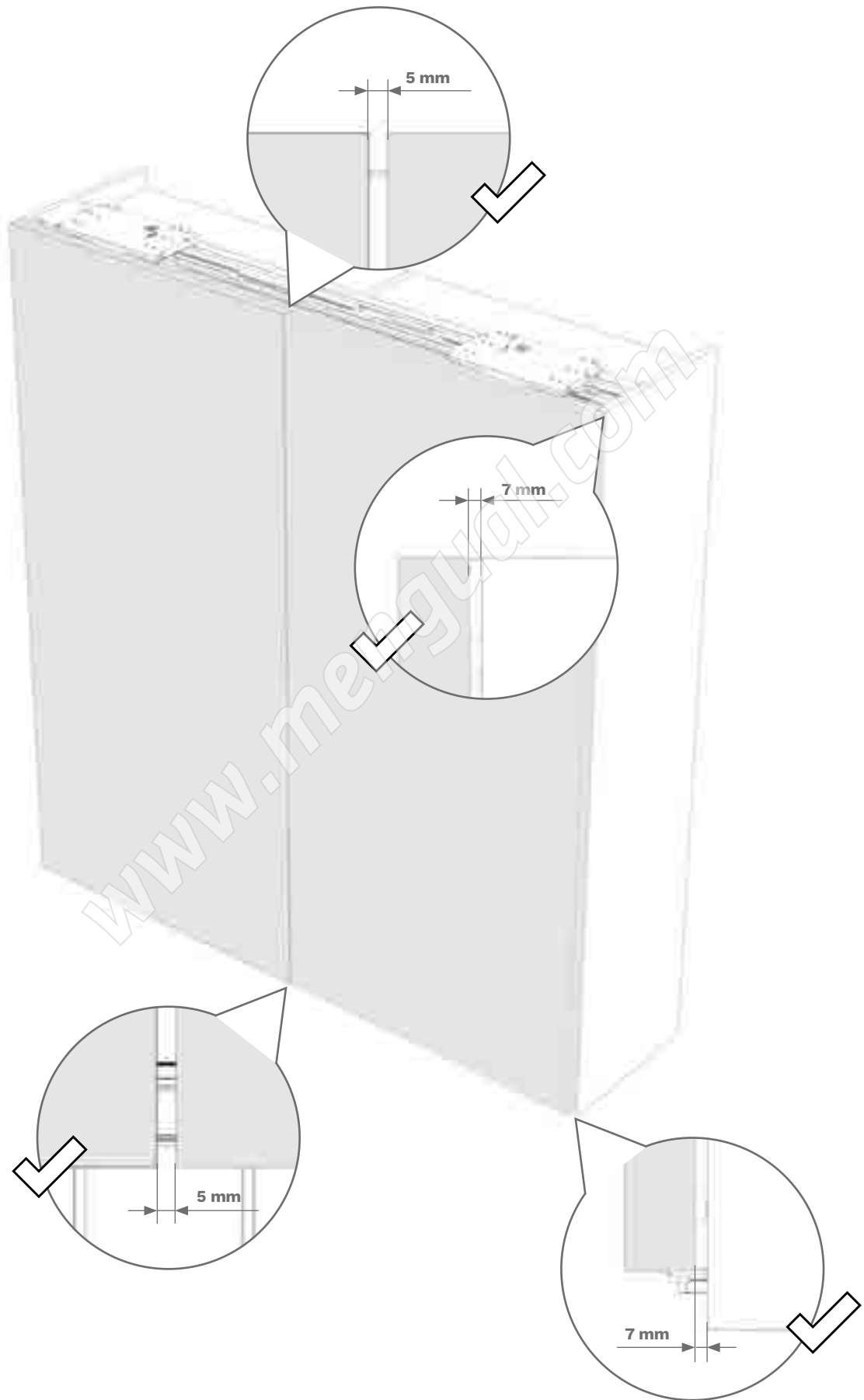

[ITA] APPLICAZIONE DEL CARTER  
COPRIPIEDINI

[ENG] APPLICATION OF THE SIDE  
SUPPORT FEET

[FRA] MISE EN PLACE DES CACHES POUR  
LES PIEDS LATÉRAUX

[DEU] ANBRINGUNG DER BLENDE FÜR  
BEIDE SEITENFÜSSE

[ESP] APLICACIÓN DEL CÁRTER  
CUBREPATAS

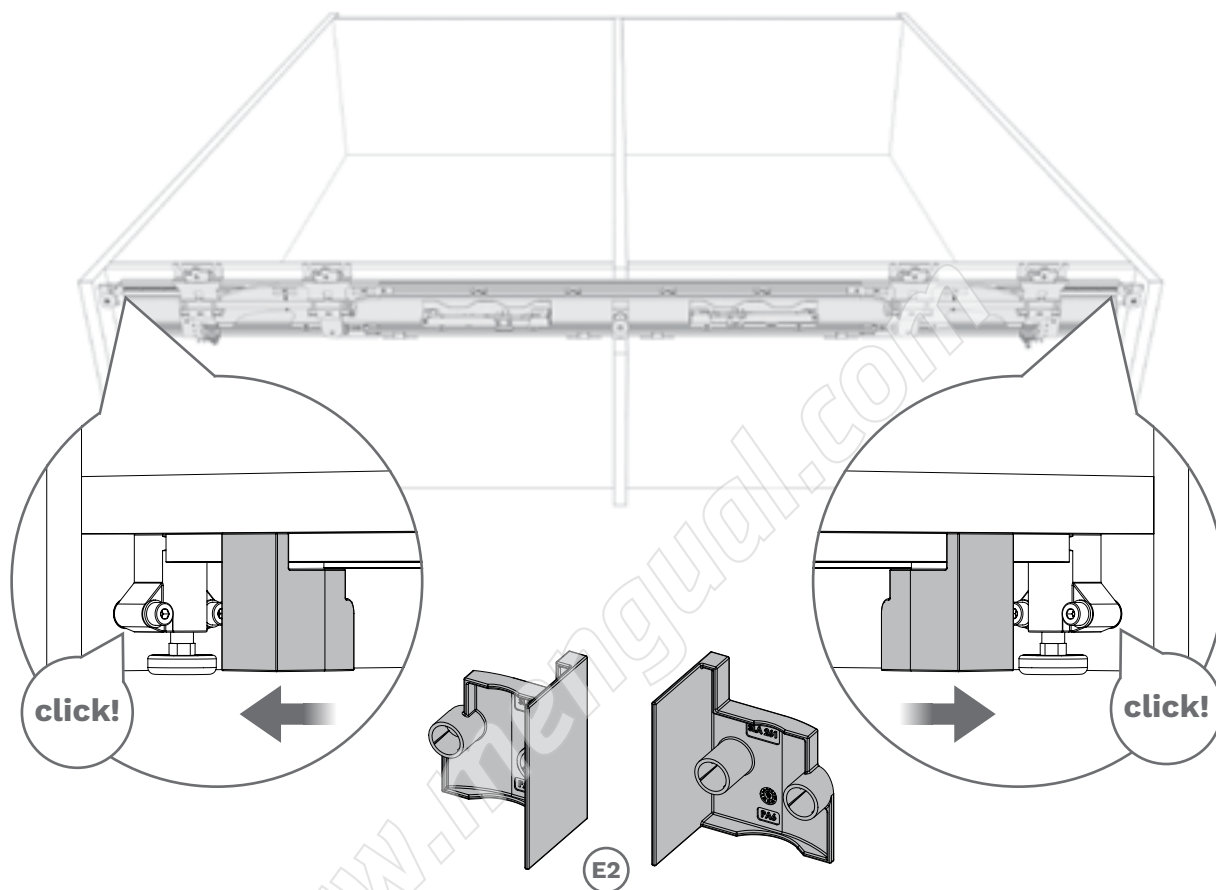

[ITA] **PROBLEMI E SOLUZIONI**

[ENG] **TROUBLESHOOTING**

[FRA] **PROBLÈMES ET SOLUTIONS**

[DEU] **PROBLEME UND LÖSUNGEN**

[ESP] **PROBLEMAS Y SOLUCIONES**

**A** Angolo anta in basso che sporge.

The bottom edge of the door does not sit flush.

Angle porte en bas en saillie.

Die Türkante unten ragt hervor.

Esquina de la puerta en la parte inferior que sobresale.

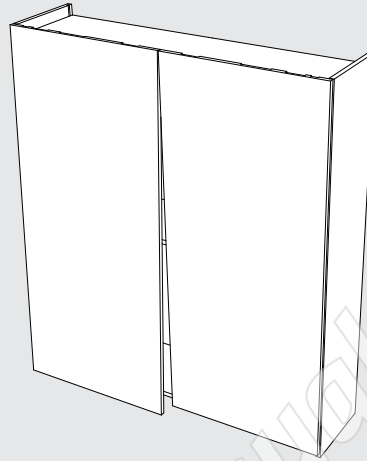

**A1** Il mobile non è ortogonale, regolare il mobile.

The cabinet is distorted, adjust the cabinet accordingly.

Le meuble n'est pas orthogonal, régler le meuble.

Der Schrank ist nicht orthogonal, bitte richten Sie den Schrank aus.

El mueble no es ortogonal, regule el mueble.

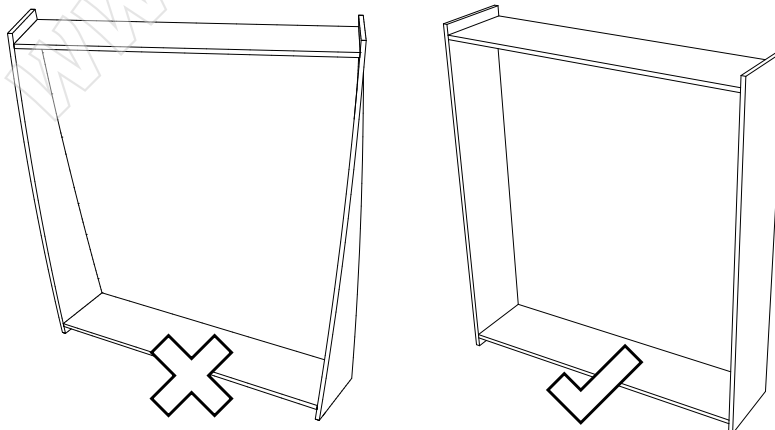

### [ITA] PROBLEMI E SOLUZIONI

### [ENG] TROUBLESHOOTING

### [FRA] PROBLÈMES ET SOLUTIONS

### [DEU] PROBLEME UND LÖSUNGEN

### [ESP] PROBLEMAS Y SOLUCIONES

**B** L'anta da aperta non è verticale.

The door in the open position is not aligned vertically.

La porte ouverte n'est pas verticale.

Die Tür in der offenen Position ist nicht senkrecht.

La puerta, cuando está abierta, no es vertical.

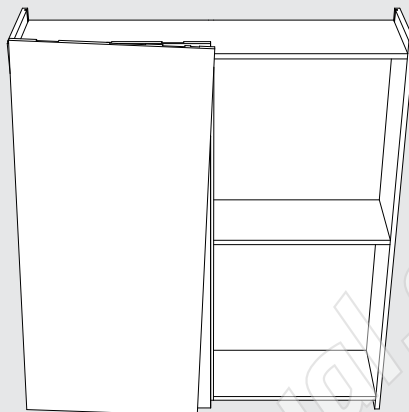

**B1** Controllare la messa in bolla dell'anta che va eseguita ad anta aperta.

With the door in the open position check that it is level.

Contrôler le nivellement de la porte qui doit être effectué avec la porte ouverte.

Die Tür in geöffneter Position ausrichten.

Controle la nivelación de la puerta que debe realizarse con la puerta abierta.

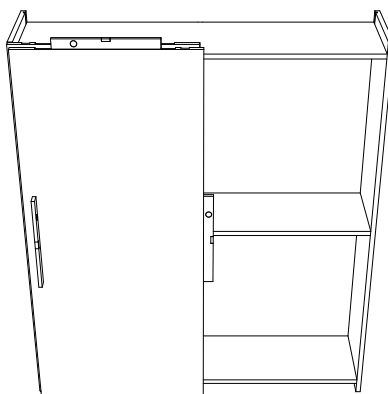

**B2** Il cielo cala sotto il peso dell'anta, inserire un montante.

The upper horizontal cabinet section bows under excessive weight, insert supplementary partition to support the load.

La voûte baisse sous le poids de la porte, insérer un montant.

Der Oberboden biegt durch unter dem Gewicht der Tür. Bitte verstärken Sie den Boden oder stellen eine zusätzlich Mittelteilseite.

El cielo cala bajo el peso de la puerta, introduzca un montante.

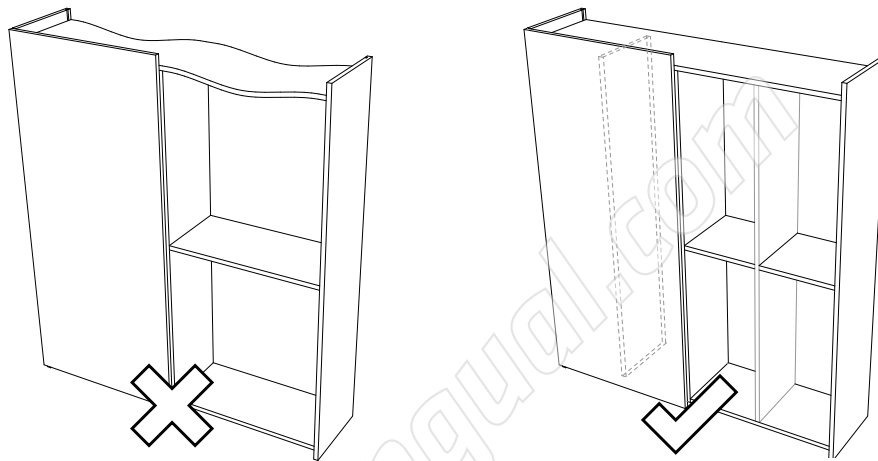

**B3** Controllare le corrette distanze tra le fresature.

Check the distances are correct between cabinet workings as per specified drawings.

Contrôler les distances correctes entre les fraisages.

Überprüfen Sie die korrekten Abstände zwischen den Frästaschen.

Controle las distancias correctas entre los fresados.

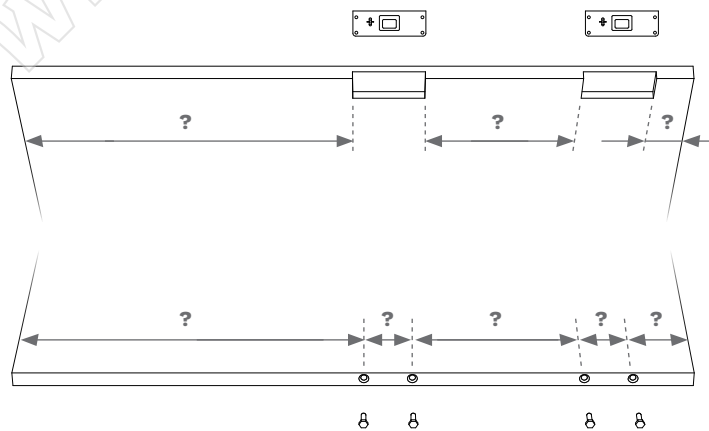

### [ITA] PROBLEMI E SOLUZIONI

### [ENG] TROUBLESHOOTING

### [FRA] PROBLÈMES ET SOLUTIONS

### [DEU] PROBLEME UND LÖSUNGEN

### [ESP] PROBLEMAS Y SOLUCIONES

**B4** Controllare, per i prodotti standard, che i due binari siano centrati rispetto al mobile.

For standard products, check that the two tracks are centered on the cabinet.

Contrôler, pour les produits standards, que les deux rails soient centrés par rapport au meuble.

Bei Standardlängen überprüfen Sie bitte, ob bei beiden Schienen der Abstand zu den Seiten gleich ist.

Controle, para los productos estándar, que las dos guías estén centradas respecto al mueble.

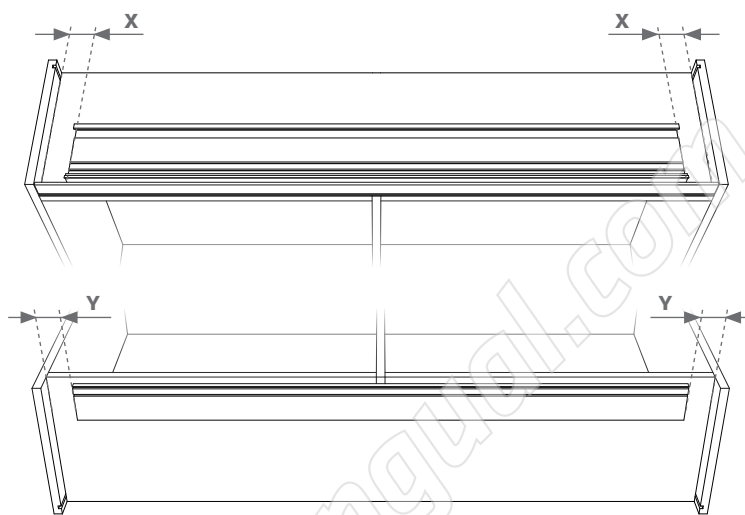

**C** L'anta non si chiude da sola, bisogna forzare.

The door does not close by itself, you have to force it.

La porte ne se ferme pas toute seule, il faut forcer.

Die Tür schließt nicht von selbst, sondern Sie müssen sie beschleunigen.

La puerta no se cierra por sí sola, hay que forzarla.

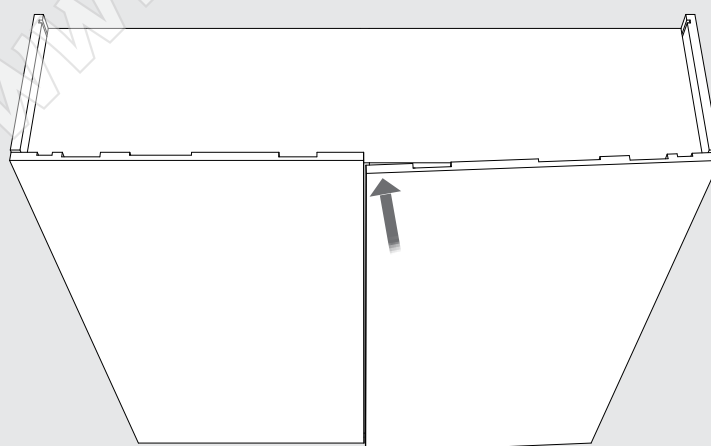

**C1** Ricontrollare le lavorazioni o la posizione dei supporti sulla parte superiore e inferiore dell'anta.

Re-check the cabinet workings. In addition check the position of the adjusters at the top and bottom of the door.

Contrôler à nouveau les usinages ou la position des supports sur la partie supérieure et inférieure de la porte.

Erneute Überprüfung der korrekten Abstände zwischen den Frästaschen, bzw. der Verstellbeschläge auf dem oberen und unteren Rand der Tür.

Controlo de nuevo las elaboraciones o la posición de los soportes en la parte superior e inferior de la puerta.

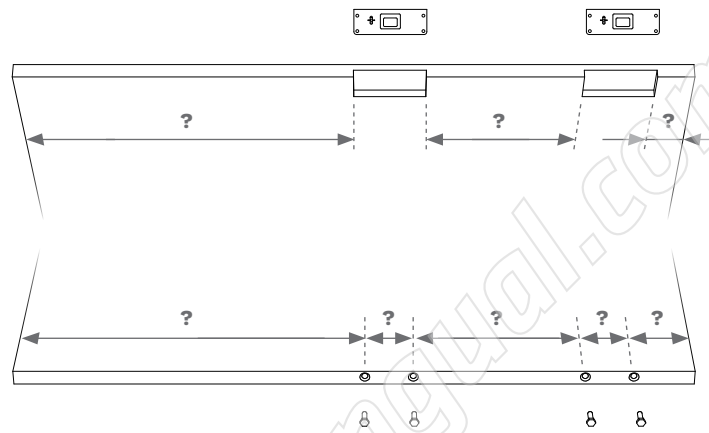

**C2** Il mobile è fuori diagonale.

The cabinet is skewed/twisted may need to be correctly aligned.

Le meuble est hors diagonale.

Der Schrank ist nicht senkrecht. Bitte exakt ausrichten.

El mueble está fuera de la diagonal.

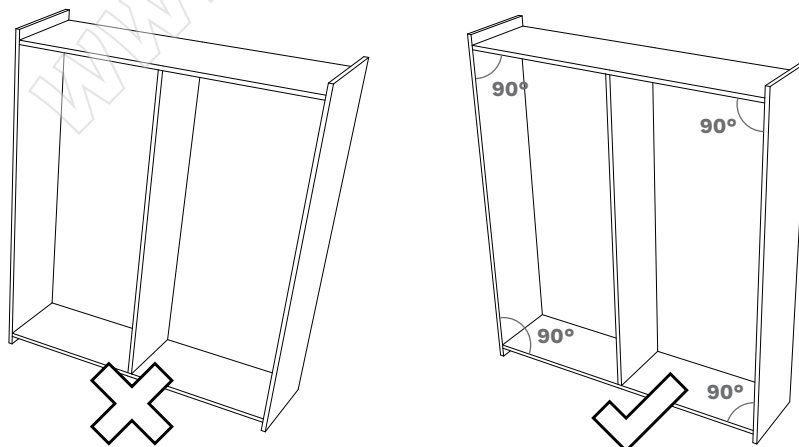

[ITA] **PROBLEMI E SOLUZIONI**

[ENG] **TROUBLESHOOTING**

[FRA] **PROBLÈMES ET SOLUTIONS**

[DEU] **PROBLEME UND LÖSUNGEN**

[ESP] **PROBLEMAS Y SOLUCIONES**

**C3** Controllare, per i prodotti standard, che i due binari siano centrati rispetto al mobile.

For standard products, check that the two tracks are centered on the cabine.

Contrôler, pour les produits standards, que les deux rails soient centrés par rapport au meuble.

Bei Standardlängen überprüfen Sie bitte, ob bei beiden Schienen der Abstand zu den Seiten gleich ist.

Controle, para los productos estándar, que las dos guías estén centradas respecto al mueble.

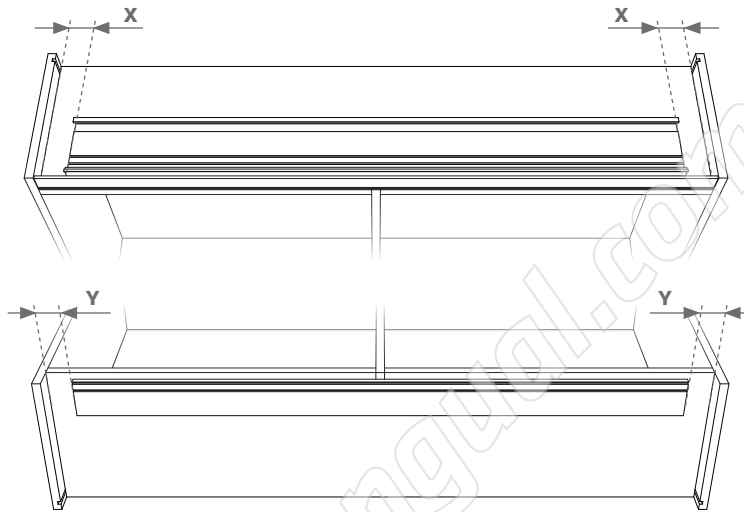

**C4** Controllare la distanza fra anta e fianco, l'anta è troppo vicina e tocca in fase di chiusura, oppure lo spazzolino è troppo alto.

Check and adjust the distance between the door and the side panel in case the door is too close and touches in the closing phase.

Contrôler la distance entre la porte et le côté, la porte est trop proche et touche en phase de fermeture, ou bien la brosse est trop haute.

Überprüfen Sie den Abstand zwischen der Tür und dem Seitenteil. Ist die Tür zu nah und berührt in der Schlussphase die Seite, ist der Abstand zu gering oder die Bürste (falls vorhanden) ist zu dick.

Controle la distancia entre la puerta y el costado, la puerta está demasiado cerca y toca en la fase de cierre o bien, el cepillo está demasiado alto.

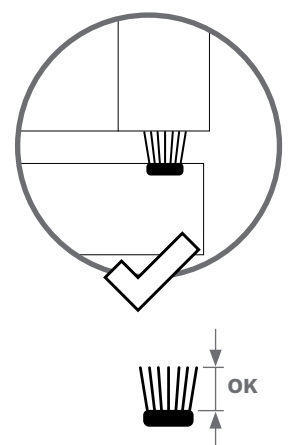
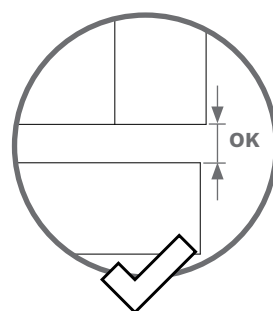
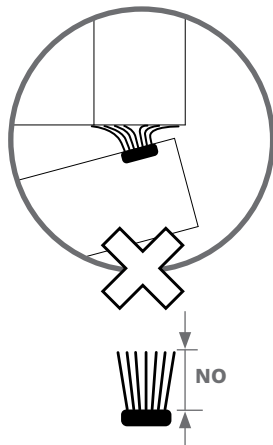
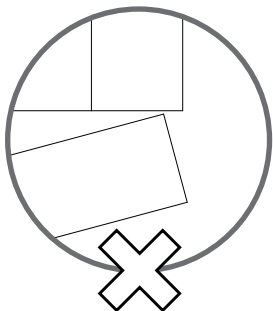
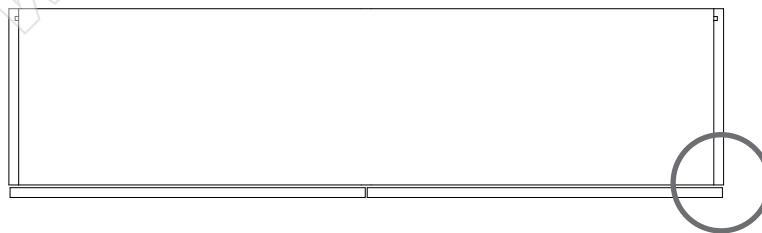

**D** L'anta rientra troppo velocemente o troppo lentamente.

The door closes too quickly, or too slowly.  
Die Tür schließt zu schnell oder zu langsam.

La porte rentre trop rapidement ou trop lentement.

La puerta regresa demasiado rápidamente o demasiado lentamente.

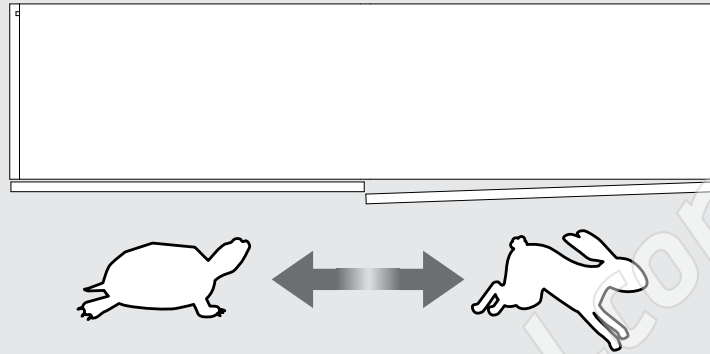

**D1** Controllare che il mobile sia in bolla.

Check that the cabinet is level.  
Überprüfen Sie, ob der Schrank senkrecht steht.

Contrôler que le meuble soit nivelé.

Controle que el mueble esté nivelado.

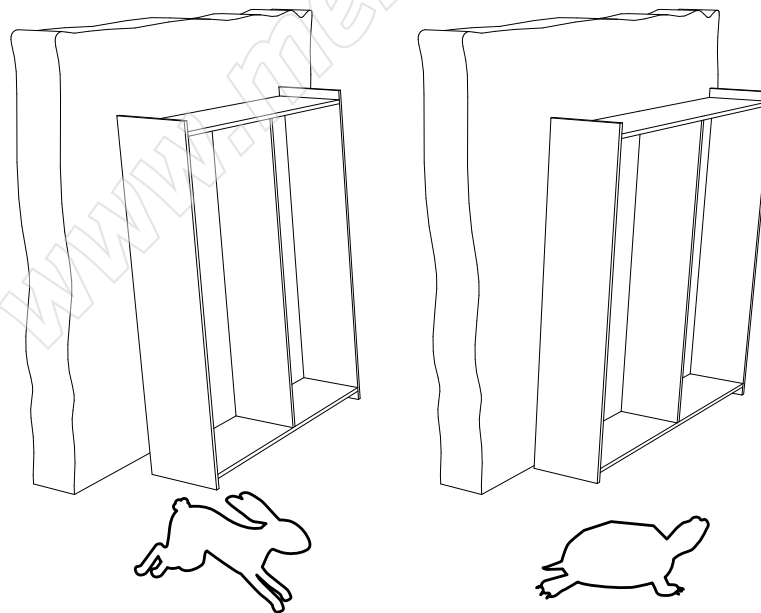

**D2** Verificare la molla di chiusura (vedi pag. 40).

Check the closing spring (see p. 40).  
Überprüfen Sie die Schließfeder (Sehen Sie Seite 40).

Vérifier le ressort de fermeture (voir le paragr. 40)

Compruebe el resorte de cierre (consulte la pág. 40).

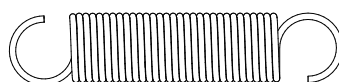

**[ITA] PROBLEMI E SOLUZIONI****[ENG] TROUBLESHOOTING****[FRA] PROBLÈMES ET SOLUTIONS****[DEU] PROBLEME UND LÖSUNGEN****[ESP] PROBLEMAS Y SOLUCIONES**

- E** Il meccanismo è rumoroso, o non scorre bene.

The mechanism is noisy, or does not run smoothly.

Le mécanisme est bruyant ou il ne glisse pas bien.

Der Mechanismus ist laut, oder läuft nicht reibungslos.

El mecanismo es ruidoso, o no se desliza correctamente.

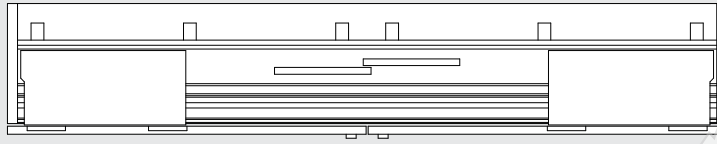

- E1** Il binario e le ruote sono sporche. Controllare e pulire con uno straccio inumidito con acqua e sapone, non utilizzando diluenti o detergenti corrosivi. Verificare che sulle ruote non vi siano residui di sporco.

The track and the wheels are dirty. Check and clean with a damp cloth using water and soap. Avoid thinners and aggressive cleaning agents. Make sure that no dirt residues are left on the wheels.

Le rail et les roues sont sales. Contrôler et nettoyer avec un chiffon humidifié avec de l'eau et du savon, sans utiliser de diluants ni détergents corrosifs. S'assurer qu'il n'y ait pas de résidus de saleté sur les roues.

Die Schiene und die Räder sind verschmutzt. Kontrollieren und mit einem mit Wasser und Seife befeuchteten Tuch reinigen; keine Verdünnungsmittel oder ätzende Reinigungsmittel verwenden. Sicherstellen, dass die Räder ohne Schmutzrückstände sind.

La guía y las ruedas están sucias. Controle y limpie con un trapo humedecido con agua y jabón, sin utilizar diluyentes o detergentes corrosivos. Compruebe que en las ruedas no haya restos de suciedad.

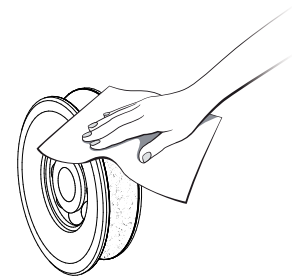
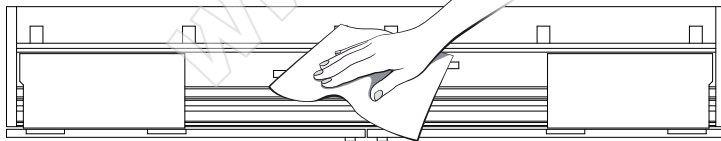

- E2** Probabilmente la ruota è stata danneggiata da un truciolo di legno o altro materiale, contattare il rivenditore per la sostituzione della ruota.

Possible damage to the rollers, contact your dealer for assistance.

La roue a probablement été endommagée par un copeau de bois ou autre matériau, contacter le revendeur pour le remplacement de la roue.

Wahrscheinlich wurde das Rad durch einen Holzspan oder einen Span von einem anderen Material beschädigt, bitte wenden Sie sich an Ihren Händler.

Probablemente la rueda ha sido dañada por una viruta de madera u otro material, contacte con el revendedor para sustituir la rueda.

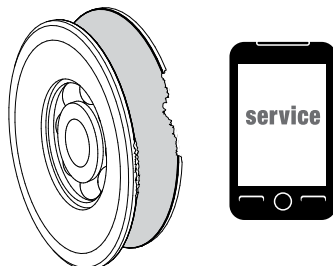

[ITA] **PULIZIA**

---

La pulizia dei componenti deve essere eseguita con un panno morbido inumidito con acqua e sapone. Vanno evitati prodotti contenenti solventi e componenti abrasivi.

**SMALTIMENTO**

Una volta dismesso, il prodotto e i suoi componenti non vanno dispersi nell'ambiente, ma conferiti ai sistemi pubblici di smaltimento.

**NOTA**

**Bortoluzzi** si riserva il diritto di apportare modifiche tecniche senza preavviso.

[ENG] **CLEANING**

---

The components must be cleaned using a soft cloth with soap and water. Avoid using products containing solvents and abrasive products.

**DISPOSAL**

The product and its components must not be disposed of in the environment; for disposal, please use public disposal systems.

**NOTE**

**Bortoluzzi** reserves the right to modify any product without prior notice.

[FRA] **NETTOYAGE**

---

Le nettoyage des composants doit être effectué avec un chiffon doux imbibé d'eau et de savon. Il faut éviter les produits contenant des solvants et des composants abrasifs.

**ÉLIMINATION**

Une fois jeté, le produit et ses composants ne peuvent pas être dispersés dans l'environnement naturel mais confiés au service public de gestion des déchets.

**REMARQUE**

**Bortoluzzi** se réserve le droit d'apporter des modifications techniques sans préavis.

[DEU] **REINIGUNG**

---

Die Reinigung der Bauteile wird mit einem mit Wasser und Seife befeuchteten, weichen Tuch ausgeführt.

**ENTSORGUNG**

Die Produkte und die Produktteile, die nicht mehr eingesetzt werden, sollen nicht in die Umwelt gelangen, sondern an den geeigneten Stellen entsorgt werden.

**HINWEIS**

**Bortoluzzi** behält sich das Recht vor, ohne vorherige Ankündigung technische Änderungen durchzuführen.

[ESP] **LIMPIEZA**

---

La limpieza de los componentes debe realizarse con un paño suave humedecido con agua y jabón. Hay que evitar productos que contengan disolventes y componentes abrasivos.

**ELIMINACIÓN**

Una vez en desuso, el producto y sus componentes no se deben echar en el medio ambiente, ya que deben entregarse a los sistemas públicos de eliminación de residuos.

**NOTA**

**Bortoluzzi** se reserva el derecho de realizar modificaciones técnicas sin preaviso.

# sliderM50

## FLEX

www.mengual.com



**bortoluzzi**

Moving silence

Bortoluzzi Sistemi SPA  
via Caduti 14 Settembre 1944, n°45  
32100 Belluno - Italy  
tel +39 0437 930866  
fax +39 0437 931442  
info@bortoluzzi.com  
www.bortoluzzi.com

