

LEES DEZE HANDLEIDING EERST AANDACHTIG EER U VAN START GAAT. HET PLAATSEN VAN DE ARGENTA[®] PIVOTICA[®] PRO DIENT TE GEBEUREN DOOR EEN VAKMAN.

LISEZ CE MODE D'EMPLOI ATTENTIVEMENT AVANT DE COMMENCER. LE MONTAGE DE L'ARGENTA[®] PIVOTICA[®] PRO DOIT ÊTRE EFFECTUÉ PAR UN PROFESSIONNEL

PLEASE READ THIS MANUAL CAREFULLY BEFORE STARTING. THE ARGENTA[®] PIVOTICA[®] PRO SHOULD ONLY BE INSTALLED BY A PROFESSIONAL.

OVERVIEW

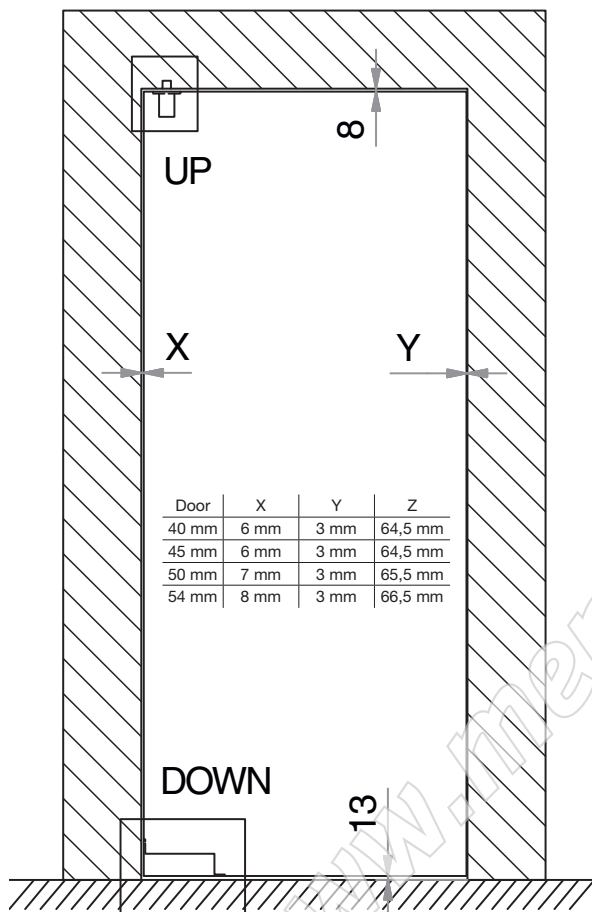

CONTENTS

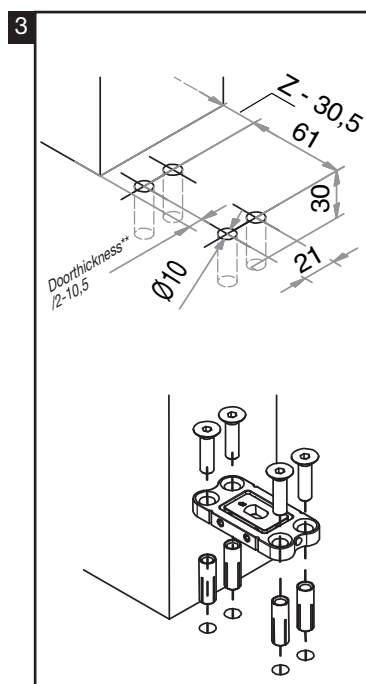
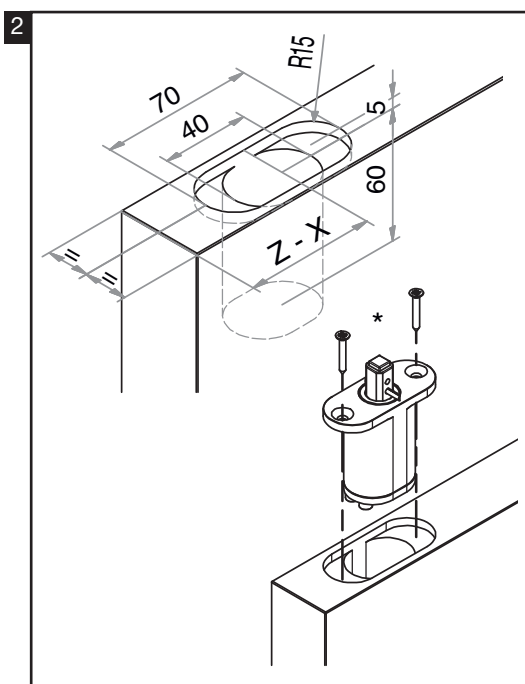
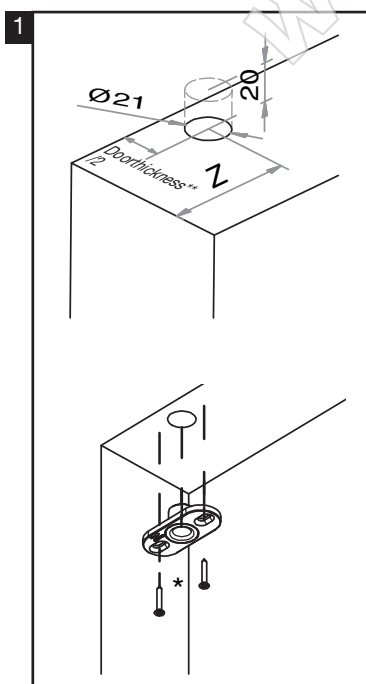
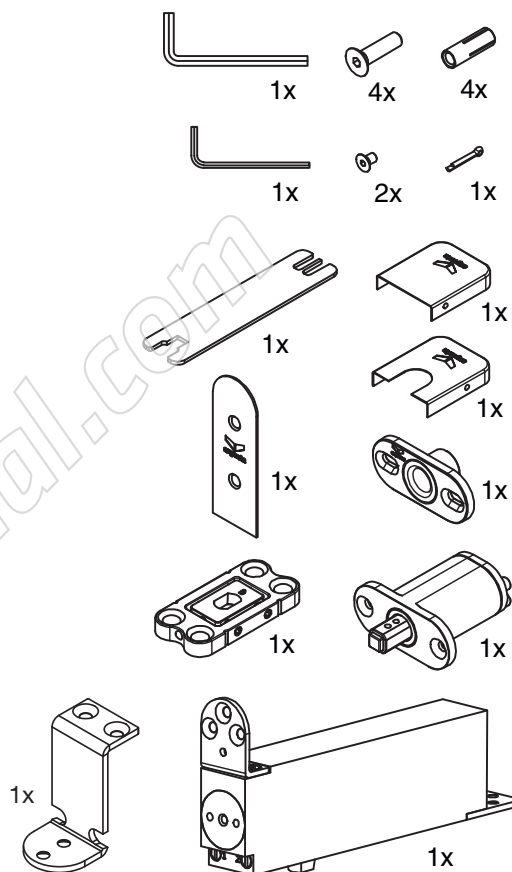

* SCHROEVEN NIET MEEGELEVERD - LES VIS NE SONT PAS INCLUS - SCREWS NOT INCLUDED

** DEURDIKTE - LARGEUR DE LA PORTE

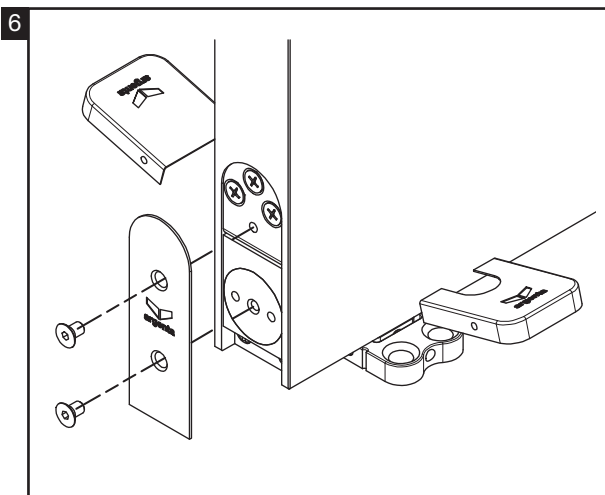
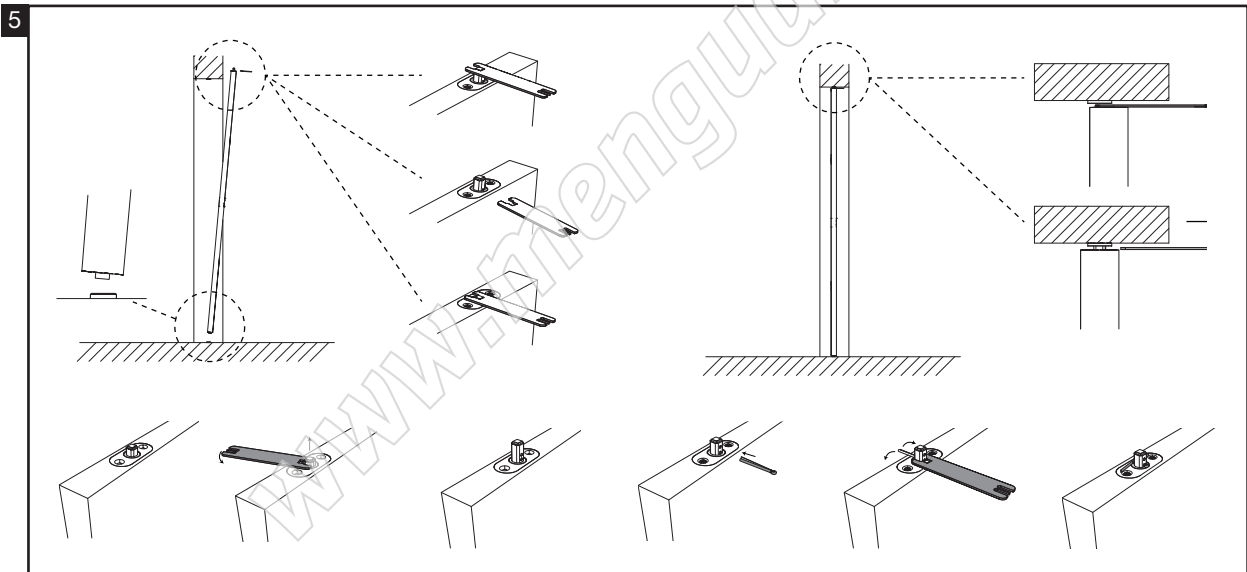
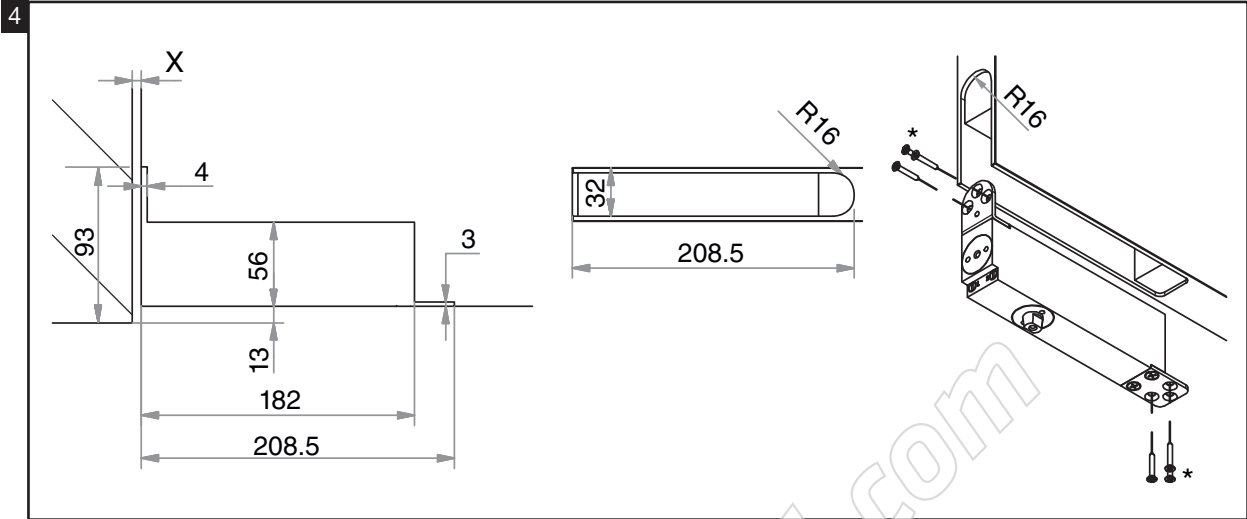

ADJUSTMENTS

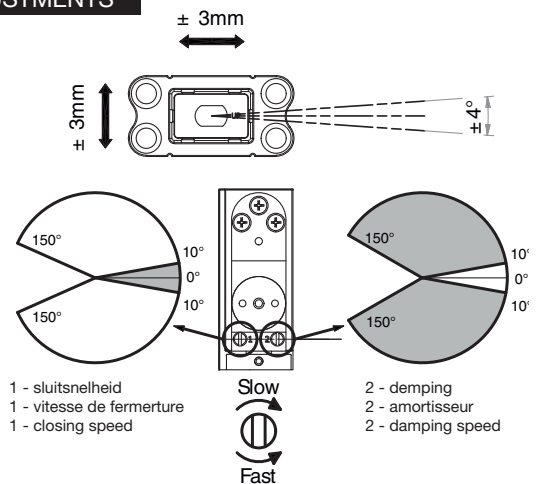

7

CENTRALE POSITIE - POSITION CENTRALE - CENTRAL POSITION

Groeven om Pivotica® PRO-C af te stellen
 Régler Pivotica® PRO-C
 Grooves to set Pivotica® PRO-C

Deurspelingen bij gebruik van minimale asafstand:
 Jeu avec positionnement minimale de l'axe:
 Gaps when using the minimal axis-distance:

Door	X	Y	Z
40 mm	6 mm	3 mm	93 mm
44 mm	5 mm	3 mm	93 mm
50 mm	6 mm	3 mm	94 mm
54 mm	6 mm	3 mm	94 mm

