

argenta®
opening doors

ARGENTA® PIVOTICA® PRO 150 F90

handleiding | mode d'emploi | Anleitung | manual

LEES DEZE HANDLEIDING EERST AANDACHTIG EER U VAN START GAAT. HET PLAATSEN VAN DE ARGENTA® PIVOTICA® PRO DIENT TE GEBEUREN DOOR EEN VAKMAN.

LISEZ CE MODE D'EMPLOI ATTENTIVEMENT AVANT DE COMMENCER. LE MONTAGE DE L'ARGENTA® PIVOTICA® PRO DOIT ÊTRE EFFECTUÉ PAR UN PROFESSIONNEL.

LESEN SIE DIESE ANLEITUNG AUFGEBERKSAM DURCH. BEVOR SIE MIT DER MONTAGE BEGINNEN. DIE MONTAGE VON ARGENTA® PROSLIDE MUSS DURCH EINEN FACHMANN ERFOLGEN.

PLEASE READ THIS MANUAL CAREFULLY BEFORE STARTING. THE ARGENTA® PIVOTICA® PRO SHOULD ONLY BE INSTALLED BY A PROFESSIONAL.

OVERVIEW

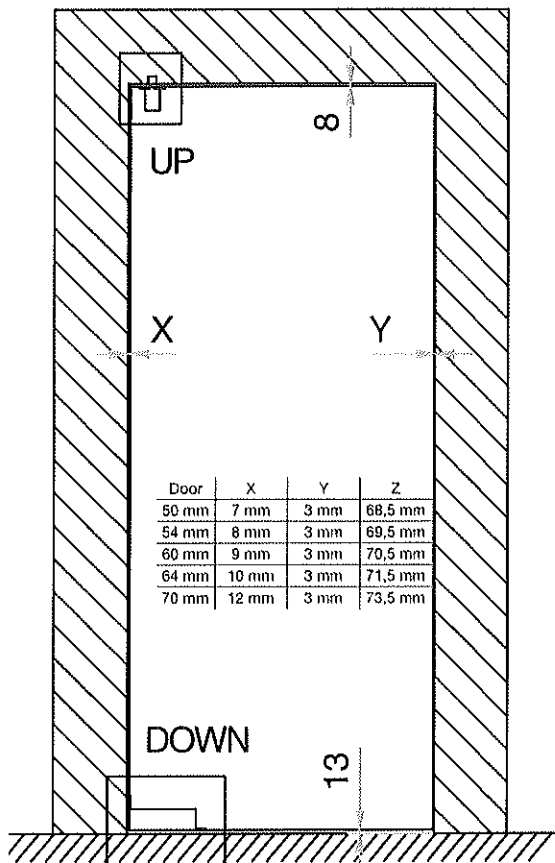

CONTENTS

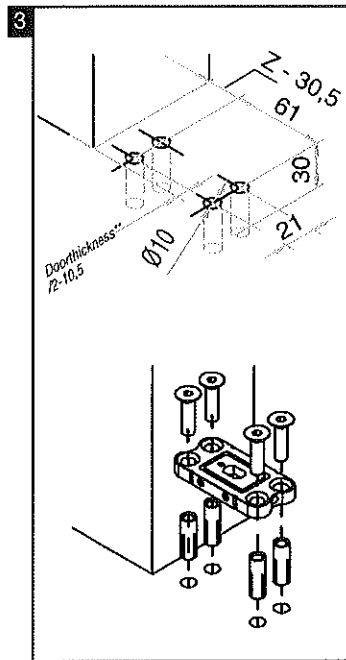
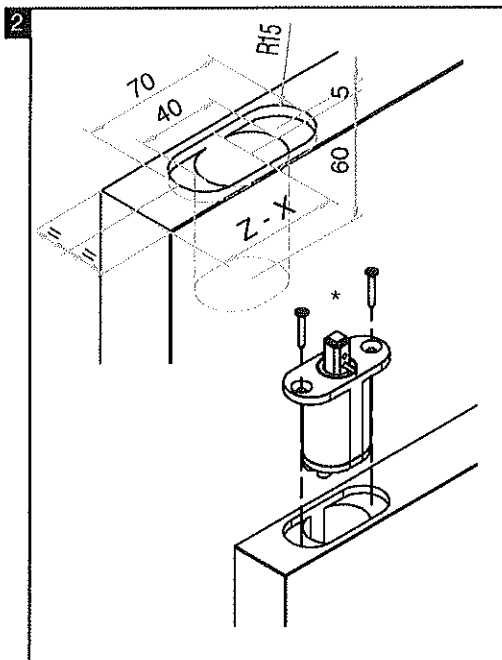
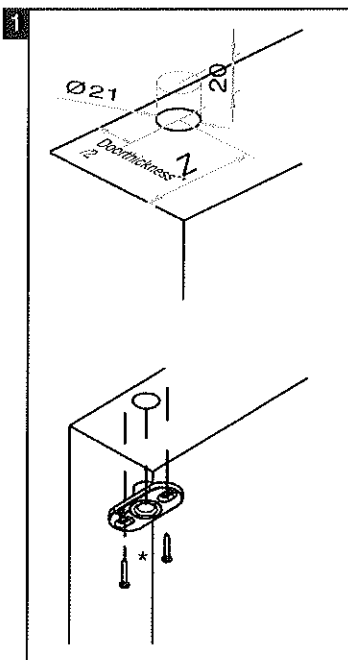
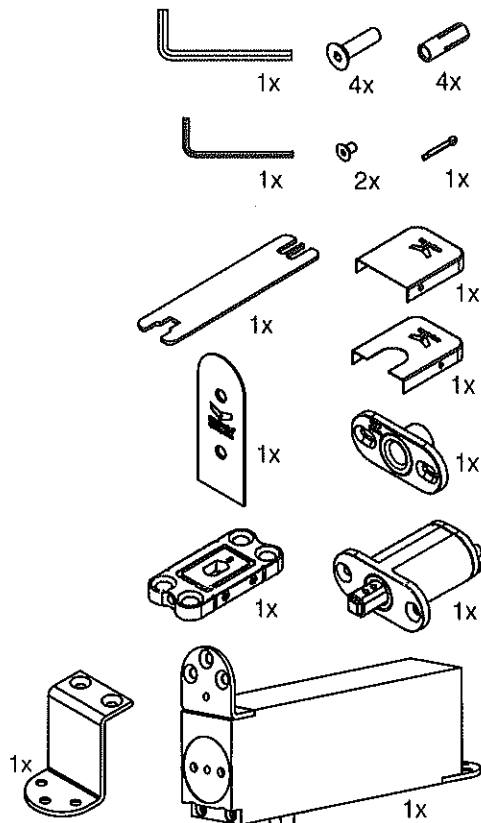

* SCHROEVEN NIET MEEGELIEVERD - LES VIS NE SONT PAS INCLUS - SCHRAUBEN NICHT MITGELIEFERT - SCREWS NOT INCLUDED
 ** DEURDIKTE - LARGEUR DE LA PORTE - TÜRDICKE - DOOR THICKNESS

ARGENTA® PIVOTICA® PRO 150 F90

handleiding | mode d'emploi | Anleitung | manual

CENTRALE POSITIE - POSITION CENTRALE - ZENTRALE POSITIONEN - CENTRAL POSITION

Groeven om Pivotica® PRO-C af te stellen
 Réglér Pivotica® PRO-C
 Nuten zum Einstellen von Pivotica® PRO-C
 Grooves to set Pivotica® PRO-C

Deurspelingen bij gebruik van minimale asafstand:
 Jeu avec positionnement minimale de l'axe:
 Türspiel bei Gebrauch mit einer Minimalen Achsabstand:
 Gaps when using the minimal axis-distance:

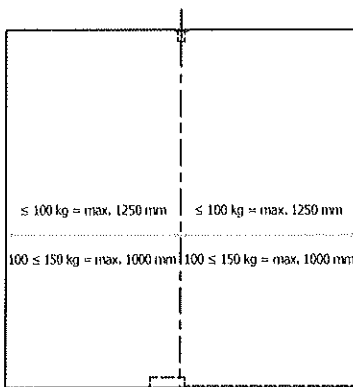

Door	X	Y	Z
50 mm	6 mm	3 mm	104,5 mm
54 mm	6 mm	3 mm	104,5 mm
60 mm	7 mm	3 mm	105,5 mm
64 mm	8 mm	3 mm	106,5 mm
70 mm	9 mm	3 mm	107,5 mm

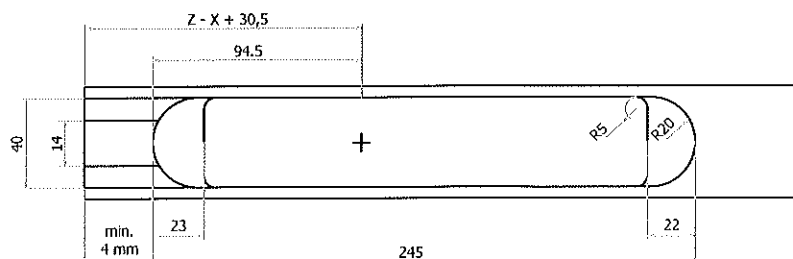
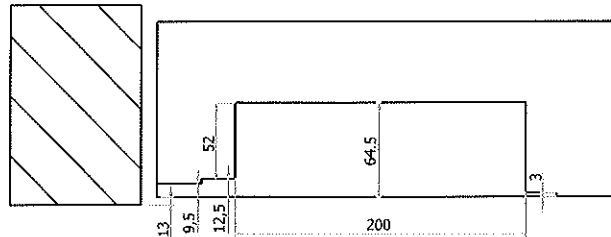
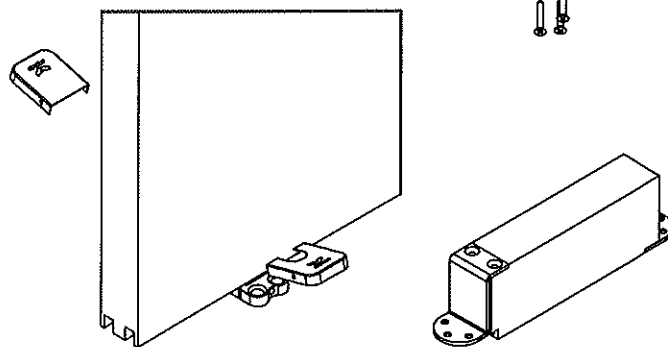
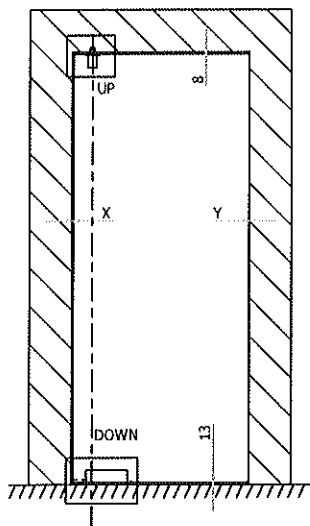
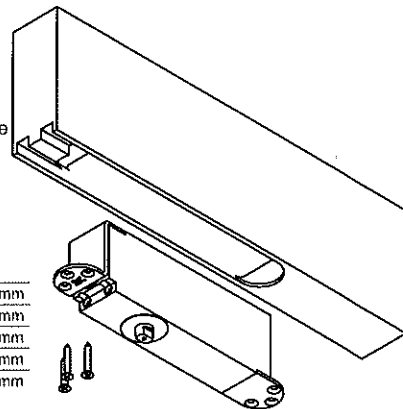

ARGENTA[®] PIVOTICA[®] PRO 150 F90

handleiding | mode d'emploi | Anleitung | manual

