

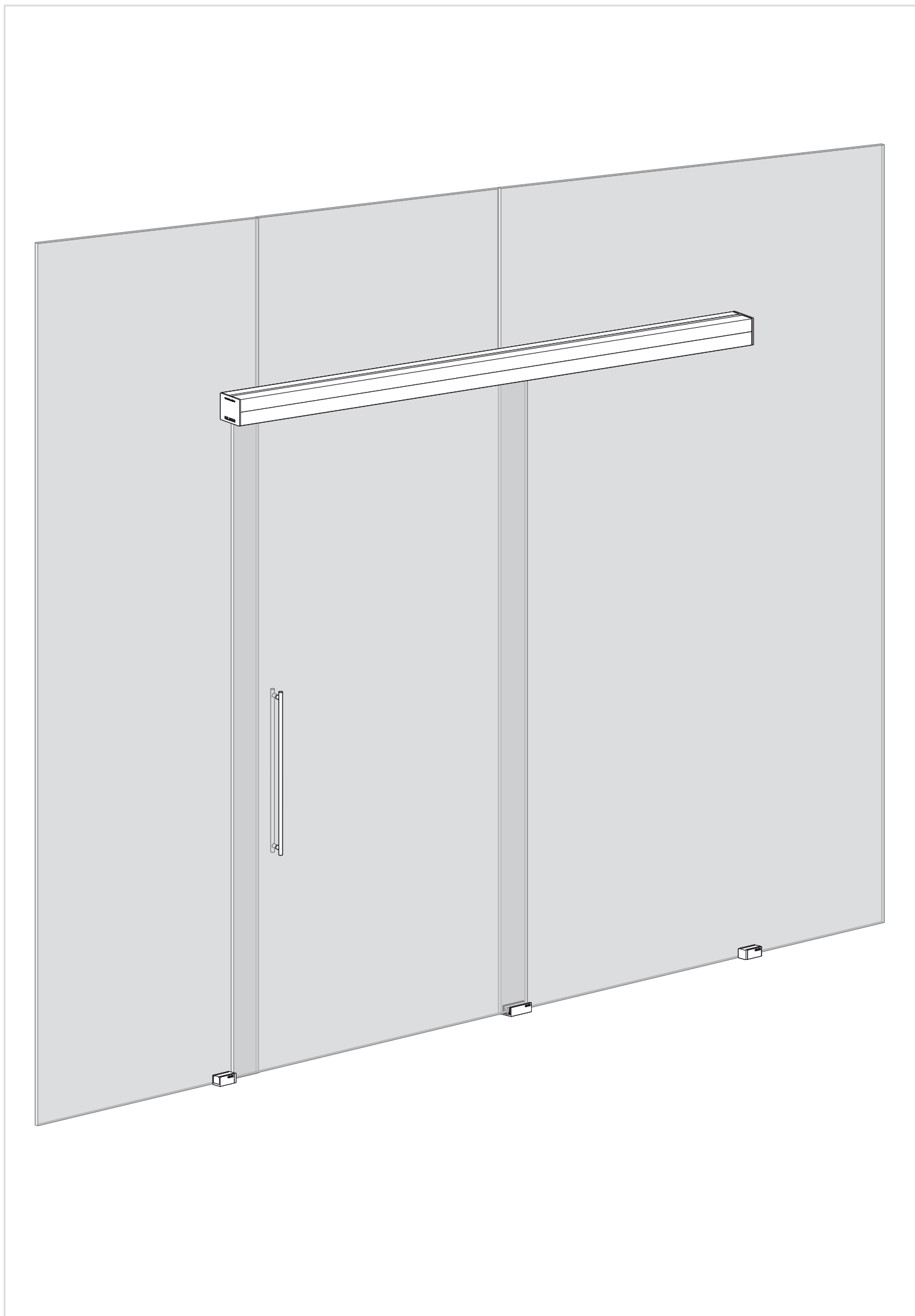

Instrucciones / Instructions / Anweisungen / Instructions

# UNIKGLASS+ AIR KBS+

		PAG.
1	IMAGEN GENERAL GENERAL VIEW	3
2	INFORMACIÓN DE SEGURIDAD SAFETY INFORMATION	4
3	HERRAMIENTAS NECESARIAS REQUIRED TOOLS	4
4	INFORMACIÓN GENERAL GENERAL INFORMATION	4
5	ELEMENTOS DE LA INSTALACIÓN ITEMS OF INSTALLATION	5
6	GAMAS DE INSTALACIÓN INSTALLATION RANGES	6
	G1 Longitud del perfil 2 m Lenght of the track 78 3/4"	6
	G2 Longitud del perfil 2,5 m Lenght of the track 98 3/8"	7
	G3 Longitud del perfil 3 m Lenght of the track 118 1/8"	8
7	MONTAJE PERFIL SUPERIOR UPPER TRACK MOUNTING	9
8	COLOCACIÓN DE MORDAZAS CLAMP INSTALL	10
9	COLOCACIÓN DEL GUIADOR GUIDE INSTALL	10
10	COLOCACIÓN DE LA PUERTA DOOR MOUNTING	11
11	REGULACIÓN DE LA ALTURA HEIGHT ADJUSTMENT	11
12	ANTIDESCABALGAMIENTO ANTI-JUMP	11
13	COLOCACIÓN DE LOS TOPES INFERIORES BOTTOM STOPPERS INSTALL	12
14	COLOCACIÓN DE LOS KBS+ KBS+ INSTALL	13
15	COLOCACIÓN DE LA GALERÍA VALANCE INSTALL	14
16	COLOCACIÓN DE LAS TAPAS LATERALES END CAP INSTALL	14



### El vidrio de la puerta corredera debe cumplir con las normas:

- UNE EN 572-2:2012 Vidrio para la edificación. Productos básicos de vidrio de silicato sodocálcico. Parte 2: Vidrio plano.
- UNE EN 12150-1:2016 Vidrio para la edificación. Vidrio de silicato sodocálcico de seguridad templado térmicamente. Parte 1: Definición y descripción.
- UNE EN ISO 12543-1/6:2011 Vidrio para la edificación. Vidrio laminado y vidrio laminado de seguridad.

### Sliding glass door must meet the requirements of:

- UNE EN 572-2:2012 Glass in building. Basic soda lime silicate glass products. Part 2: Float glass.
- UNE EN 12150-1:2016 Glass in Building. Thermally toughened soda lime silicate safety glass. Part 1: Definition and description.
- UNE EN ISO 12543-1/6:2011 Glass in building. Laminated glass and laminated safety glass.

## 3 HERRAMIENTAS NECESARIAS / REQUIRED TOOLS

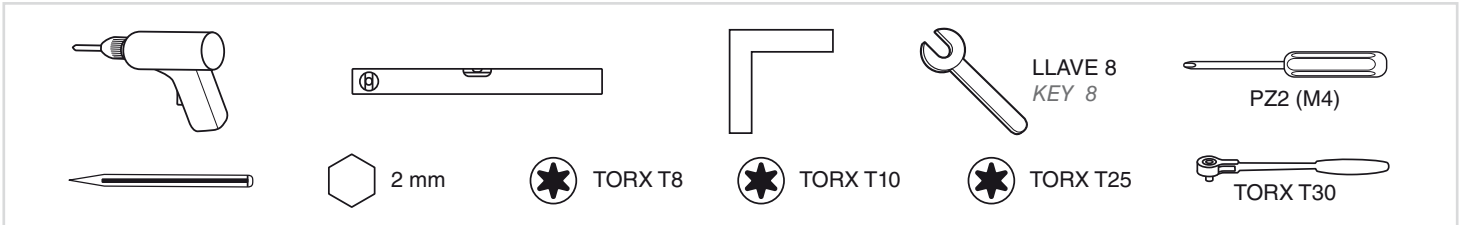

## 4 INFORMACIÓN GENERAL / GENERAL INFORMATION

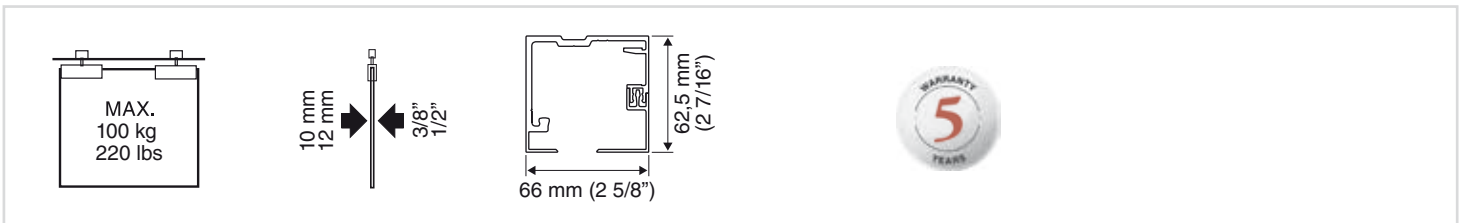

### ALTURA DEL VIDRIO / GLASS HEIGHT

Aplicar la fórmula para determinar la altura del cristal según el tipo de instalación  
Apply the formula to determine the glass height according to the type of installation

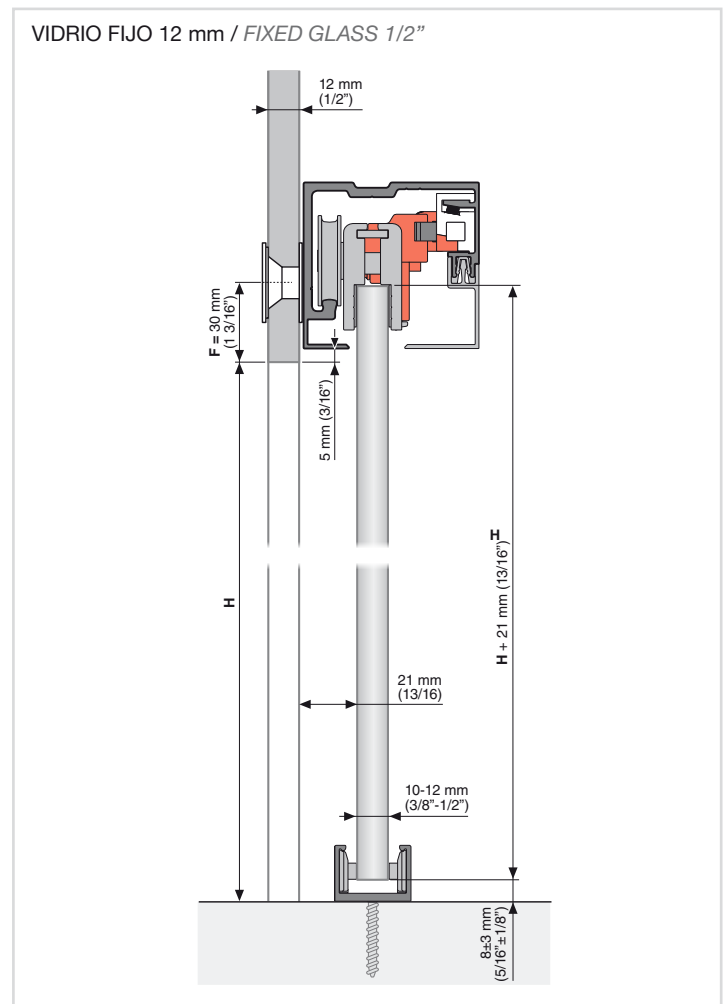
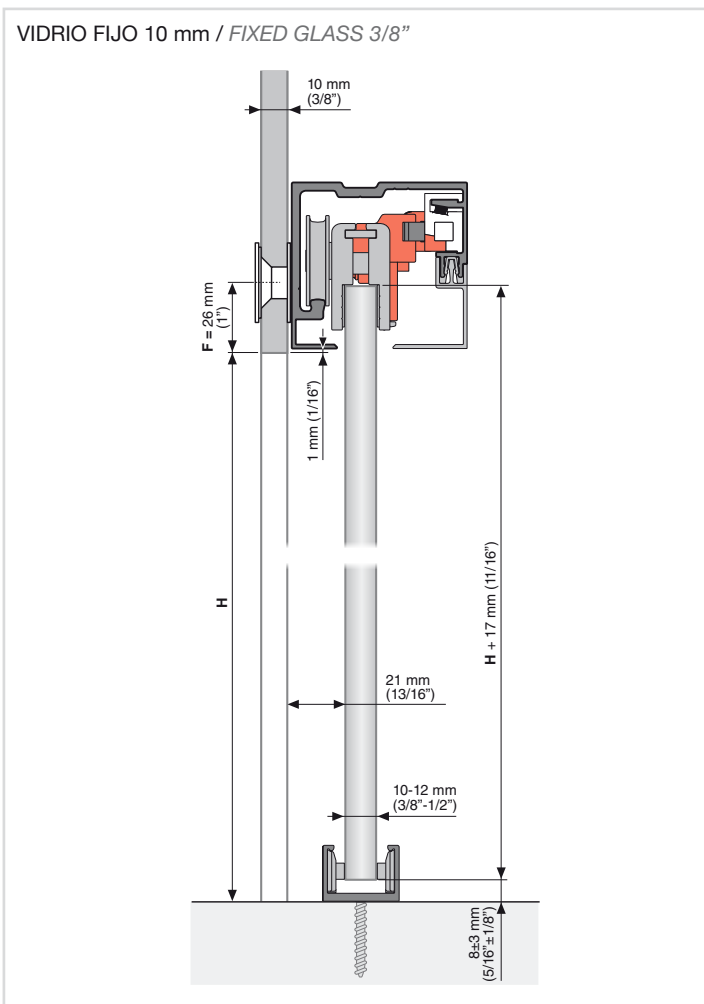

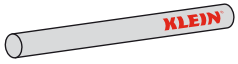

## INST. UNIKGLASS+ AIR KBS+ KIT UNIKGLASS+ AIR KBS+

**SILVER**  
Ref. 2670 - G1 2 m (78 3/4")  
Ref. 2671 - G2 2,5 m (98 3/8")  
Ref. 2672 - G3 3 m (118 1/8")

**BLACK**  
Ref. 2680 - G1 2 m (78 3/4")  
Ref. 2681 - G2 2,5 m (98 3/8")  
Ref. 2682 - G3 3 m (118 1/8")

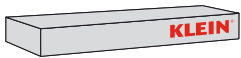
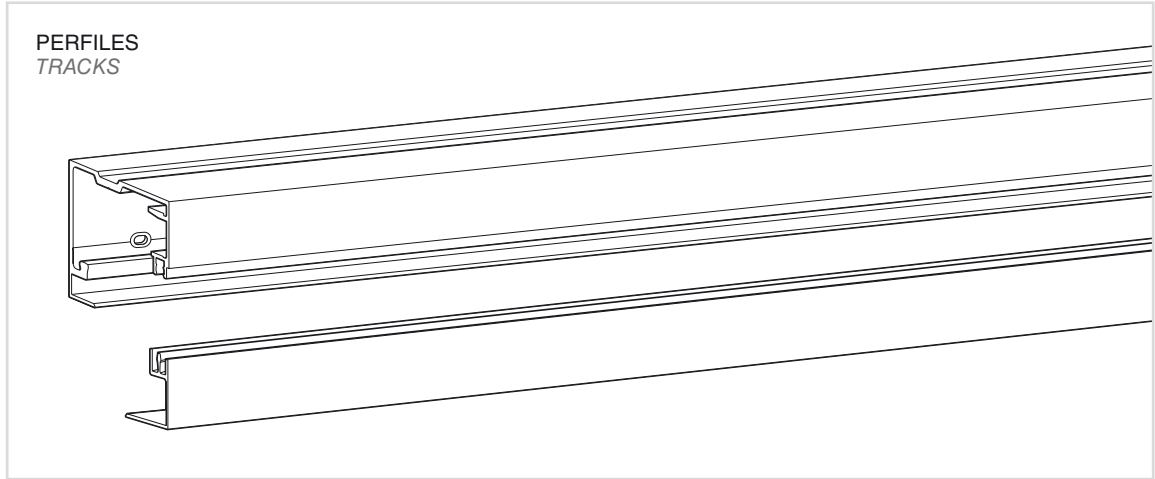

## JUEGO DE ACCESORIOS SET OF ACCESSORIES

Mordaza  
Clamp

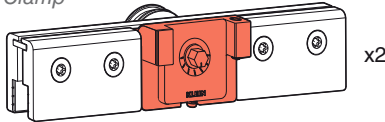

x2

KBS+

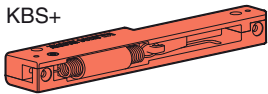

x2

Clips conexión perfiles superiores  
Clips for upper tracks connections

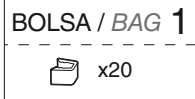

x20

Tornillos Anclaje a Vidrio Fijo  
Screws for Fixed Glass Anchor



x8

Vidrio 10 mm  
Glass 3/8"



x8

Vidrio 12 mm  
Glass 1/2"

Distanciadores mordaza  
Clamp spacers



x4  
x4

Guiador  
Guide

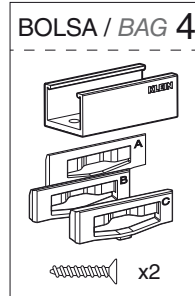

x2

Anclajes KBS+  
KBS+ anchor pieces



x4  
x4

Topes inferiores  
Bottom stoppers

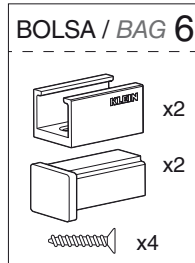

x2  
x2  
x4

Tapas laterales perfil superior  
End caps for upper track



x2

Anclajes a Vidrio Fijo  
Fixed Glass Anchors

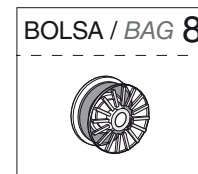

G1 2 m (78 3/4") x6  
G2 2,5 m (98 3/8") x6  
G3 3 m (118 1/8") x8

Instrucciones  
Instructions



**GAMA 1** Longitud del perfil 2 m  
Length of the track 78 3/4"



**NO CORTAR EL PERFIL**  
**DO NOT CUT THE TRACK**

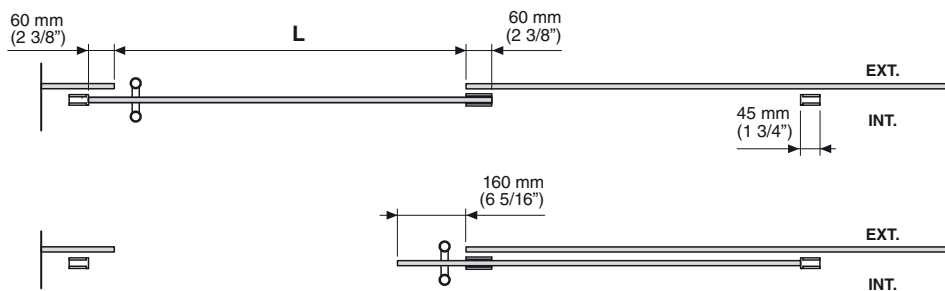
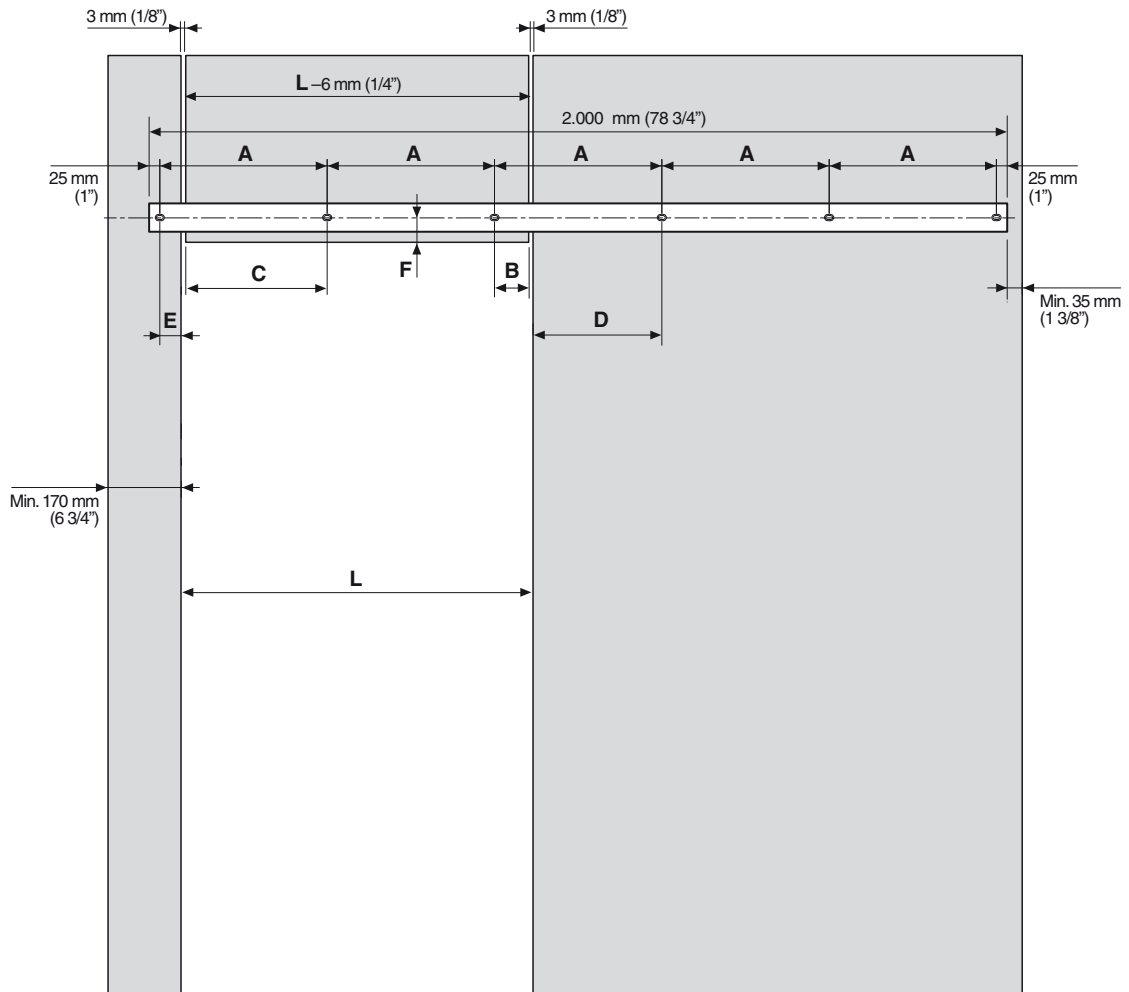

**A** = 390 mm (15 3/8")  
**C** = 337 mm (13 9/32")  
**E** = 50 mm (1 31/32")  
**F** (EN APARTADO 4)  
(GO TO CHAPTER 4)

**L:** De 820 mm hasta 970 mm  
*L: From (32 5/16") up to (38 3/16")*  
**B** = L - 733 mm (28 7/8")  
**D** = 387 mm (15 1/4") - B

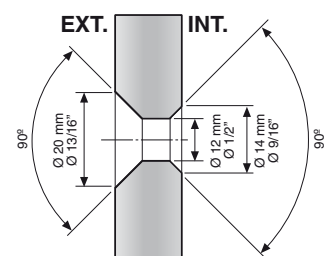

Solape mínimo de 50 mm en el guiador. / Minimum overlap of 2" at the bottom guide.  
Asegurar la posición de los 2 topes inferiores. / Make sure the position of both bottom stoppers.

**GAMA 2** Longitud del perfil 2,5 m  
*Length of the track 98 3/8"*

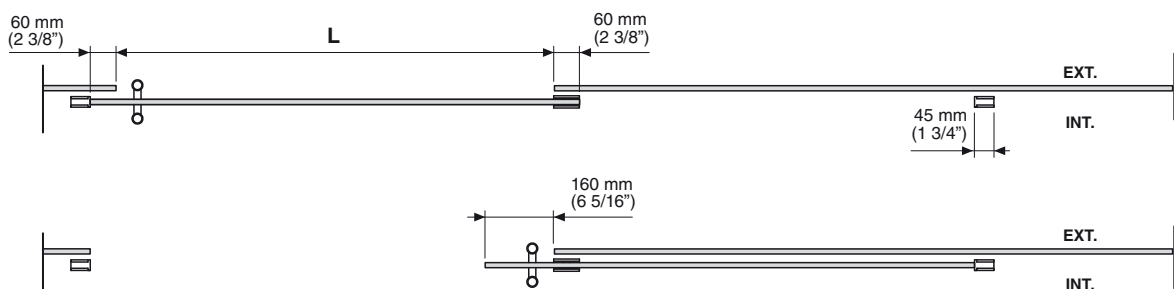
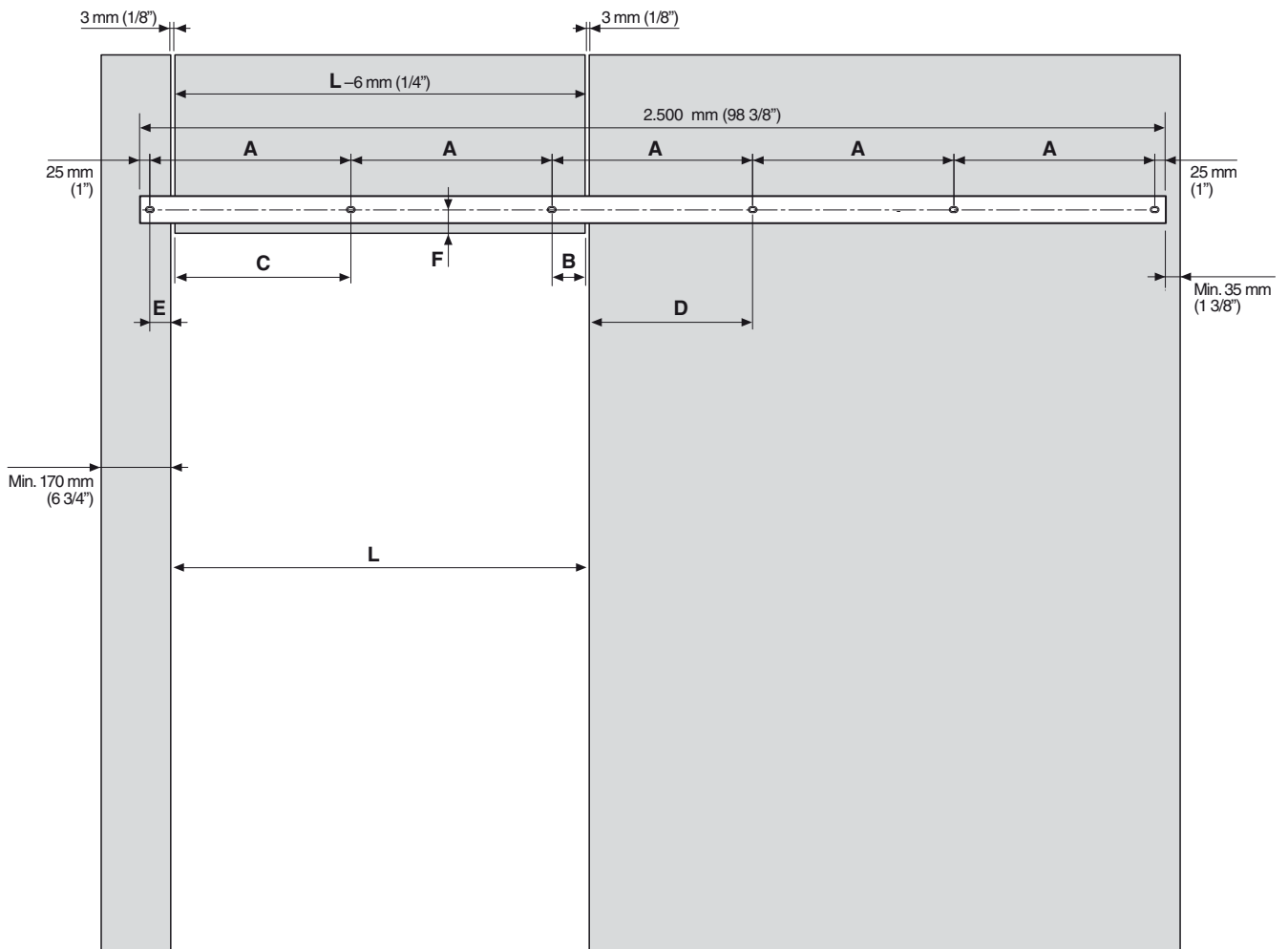
**NO CORTAR EL PERFIL**  
**DO NOT CUT THE TRACK**

**A = 490 mm (19 5/16")**  
**C = 437 mm (17 7/32")**  
**E = 50 mm (1 31/32")**  
**F (EN APARTADO 4)**  
*(GO TO CHAPTER 4)*

**L: De 1.020 mm hasta 1.220 mm**  
*L: From (40 3/16") up to (48")*  
**B = L - 933 mm (36 3/4")**  
**D = 487 mm (19 3/16") - B**

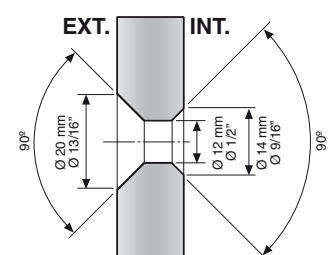

Solape mínimo de 50 mm en el guiador. / *Minimum overlap of 2" at the bottom guide.*  
 Asegurar la posición de los 2 topes inferiores. / *Make sure the position of both bottom stoppers.*

**GAMA 3** Longitud del perfil 3 m  
 Length of the track 118 1/8"

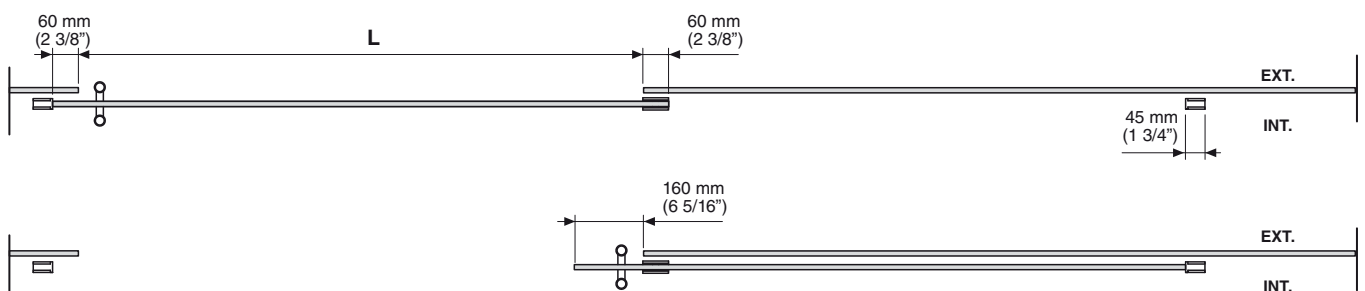
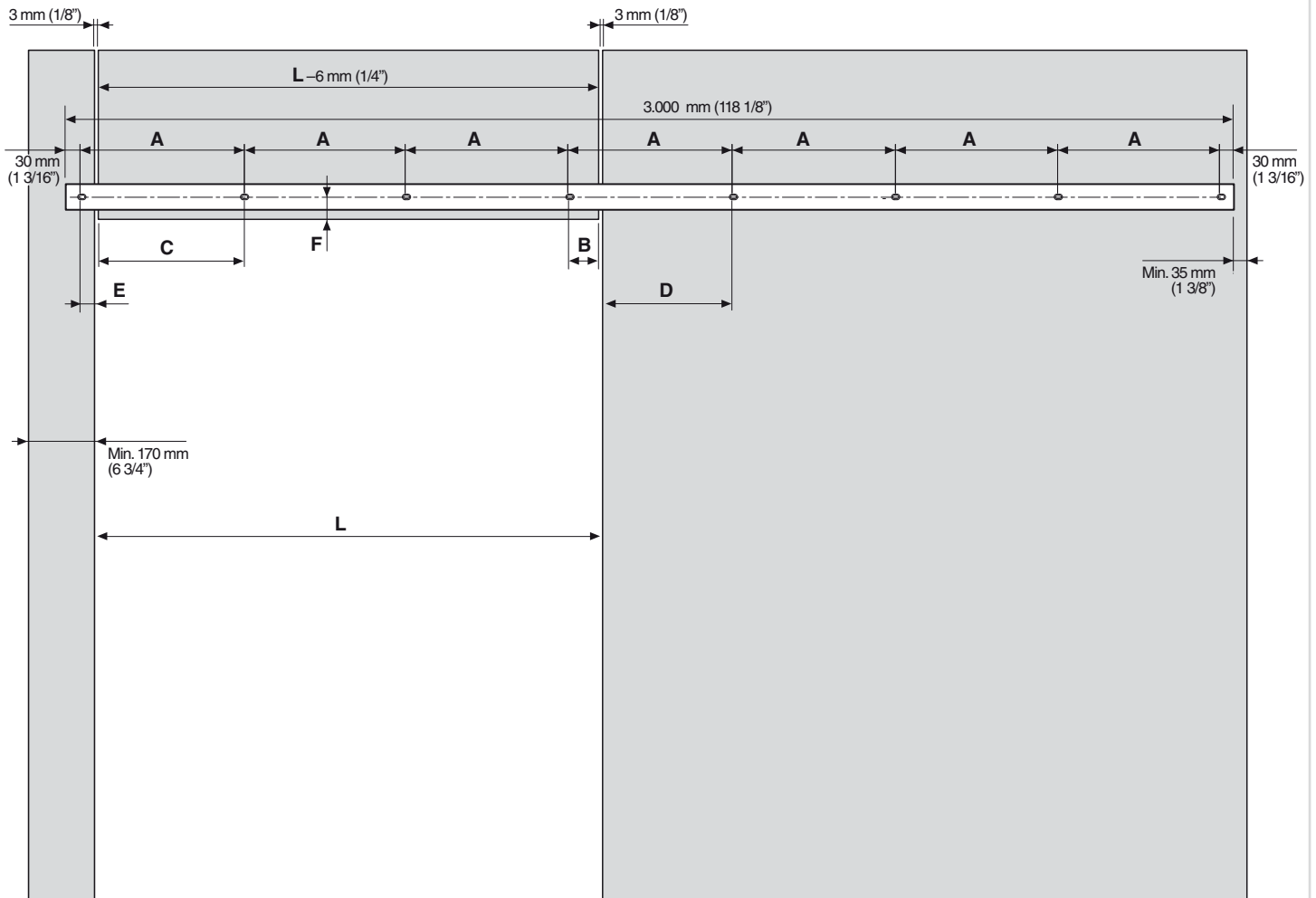
**NO CORTAR EL PERFIL**  
**DO NOT CUT THE TRACK**

**A = 420 mm (16 17/32")**  
**C = 367 mm (14 7/16")**  
**E = 50 mm (1 31/32")**  
**F (EN APARTADO 4)**  
 (GO TO CHAPTER 4)

**L: De 1.300 mm hasta 1.470 mm**  
**L: From (51 3/16") up to (57 7/8")**  
**B = L - 1.213 mm (47 3/4")**  
**D = 417 mm (16 13/32") - B**

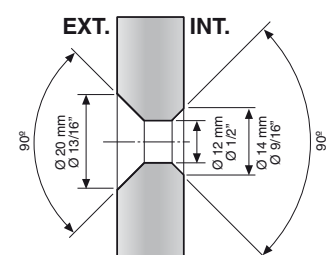

Solape mínimo de 50 mm en el guidor. / Minimum overlap of 2" at the bottom guide.  
 Asegurar la posición de los 2 topes inferiores. / Make sure the position of both bottom stoppers.



MONTAJE ANCLAJES A VIDRIO FIJO / FIXED GLASS ANCHORS MOUNTING

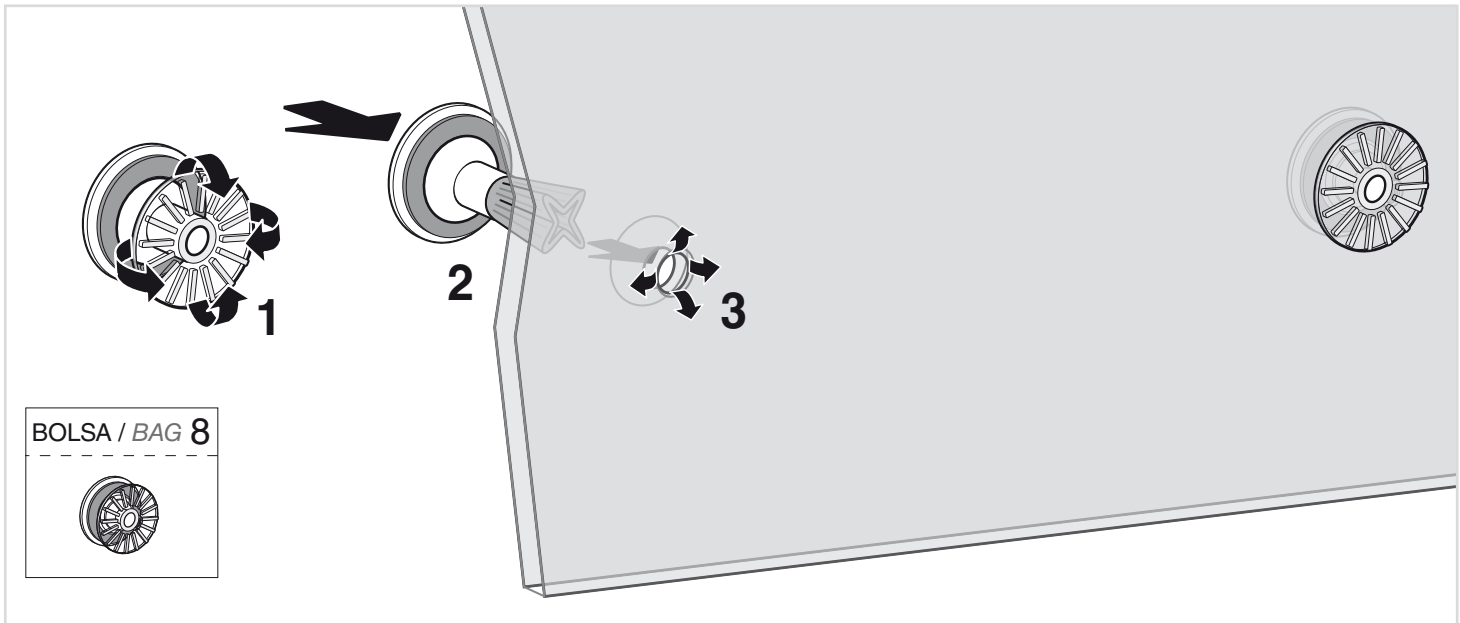

MONTAJE PERFIL SUPERIOR / UPPER TRACK MOUNTING

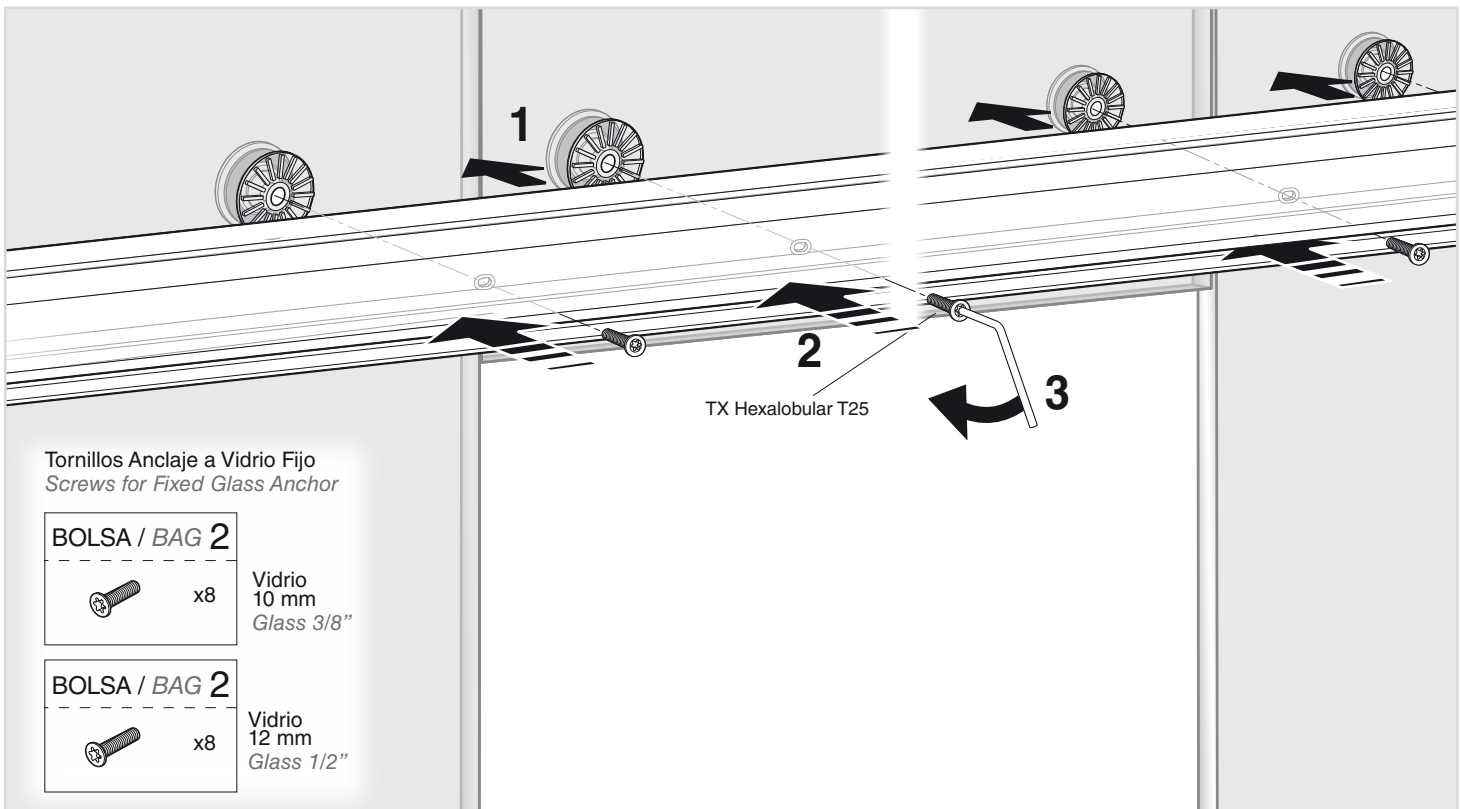

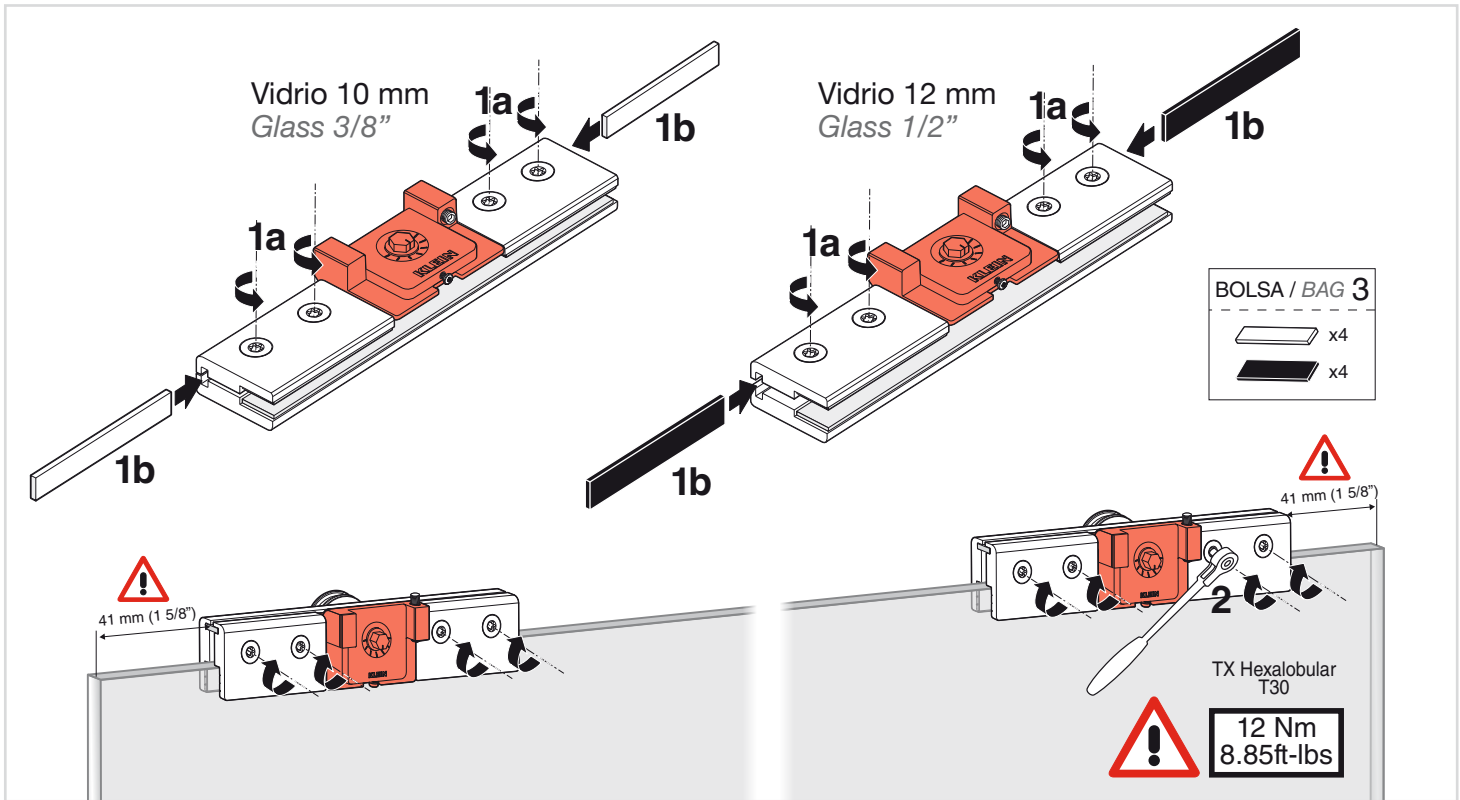

9 COLOCACIÓN DEL GUIADOR / GUIDE INSTALL

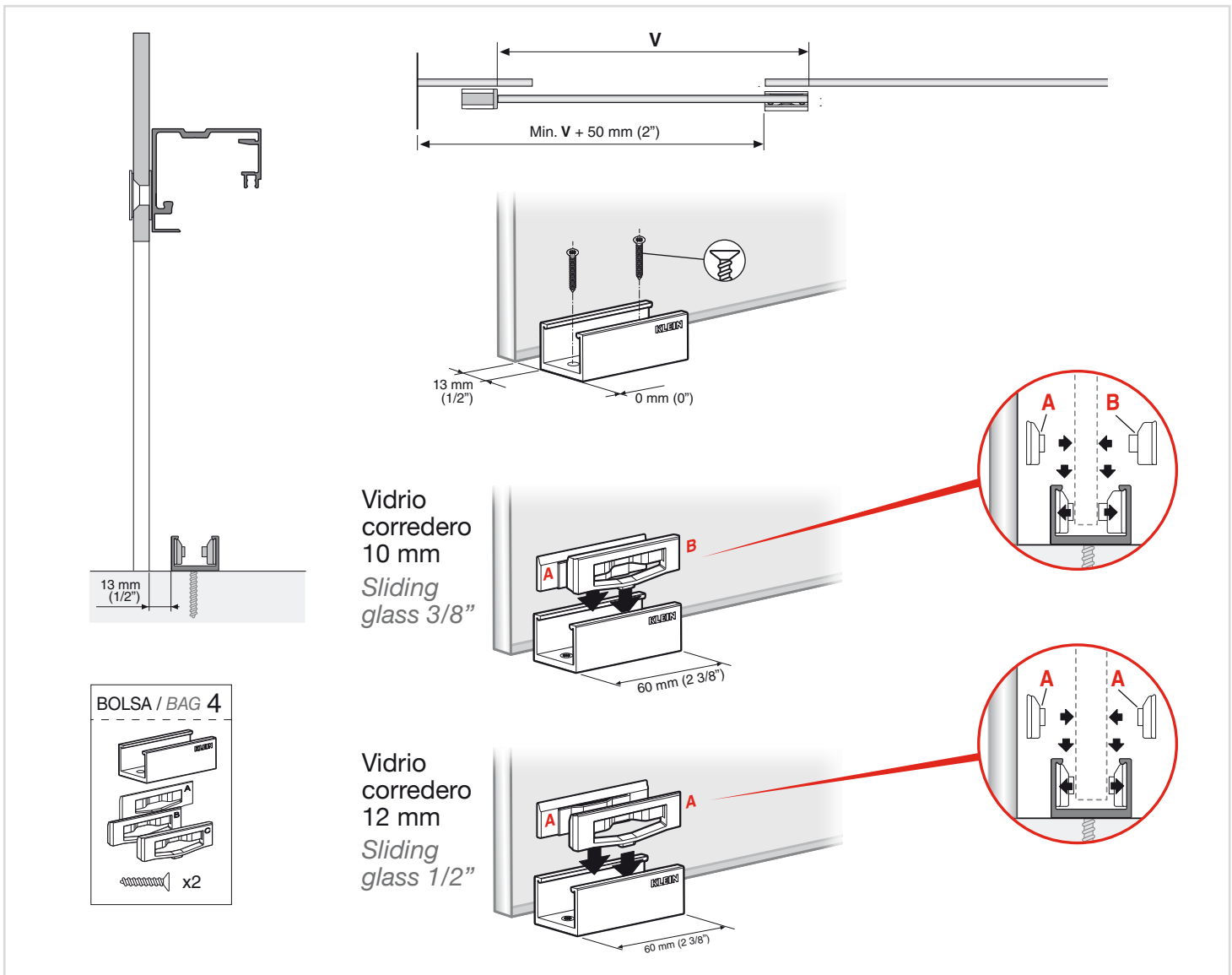

# 10 COLOCACIÓN DE LA PUERTA / DOOR MOUNTING

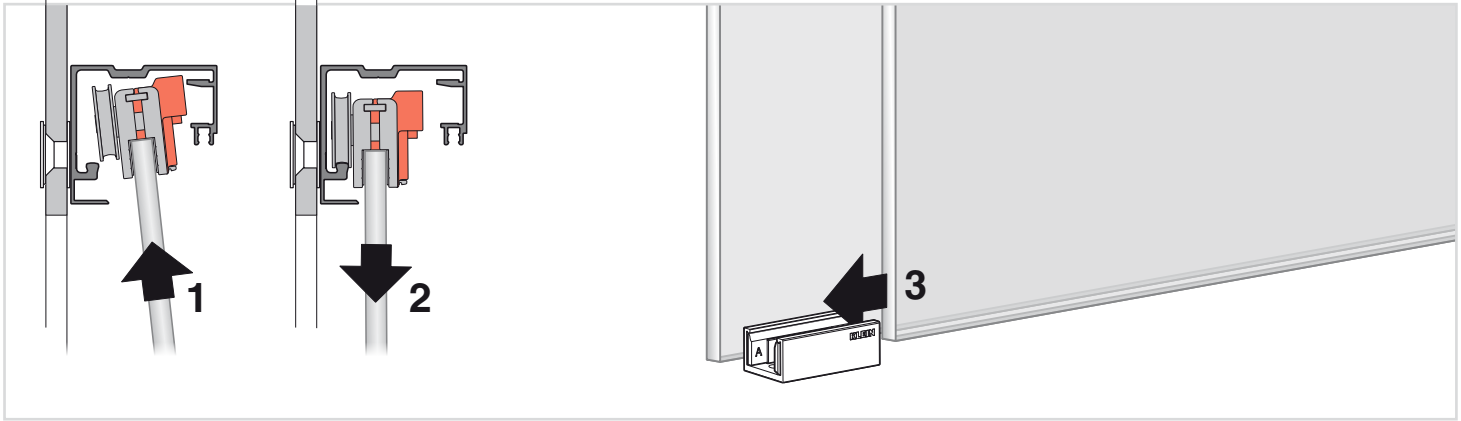

# 11 REGULACIÓN DE LA ALTURA / HEIGHT ADJUSTMENT

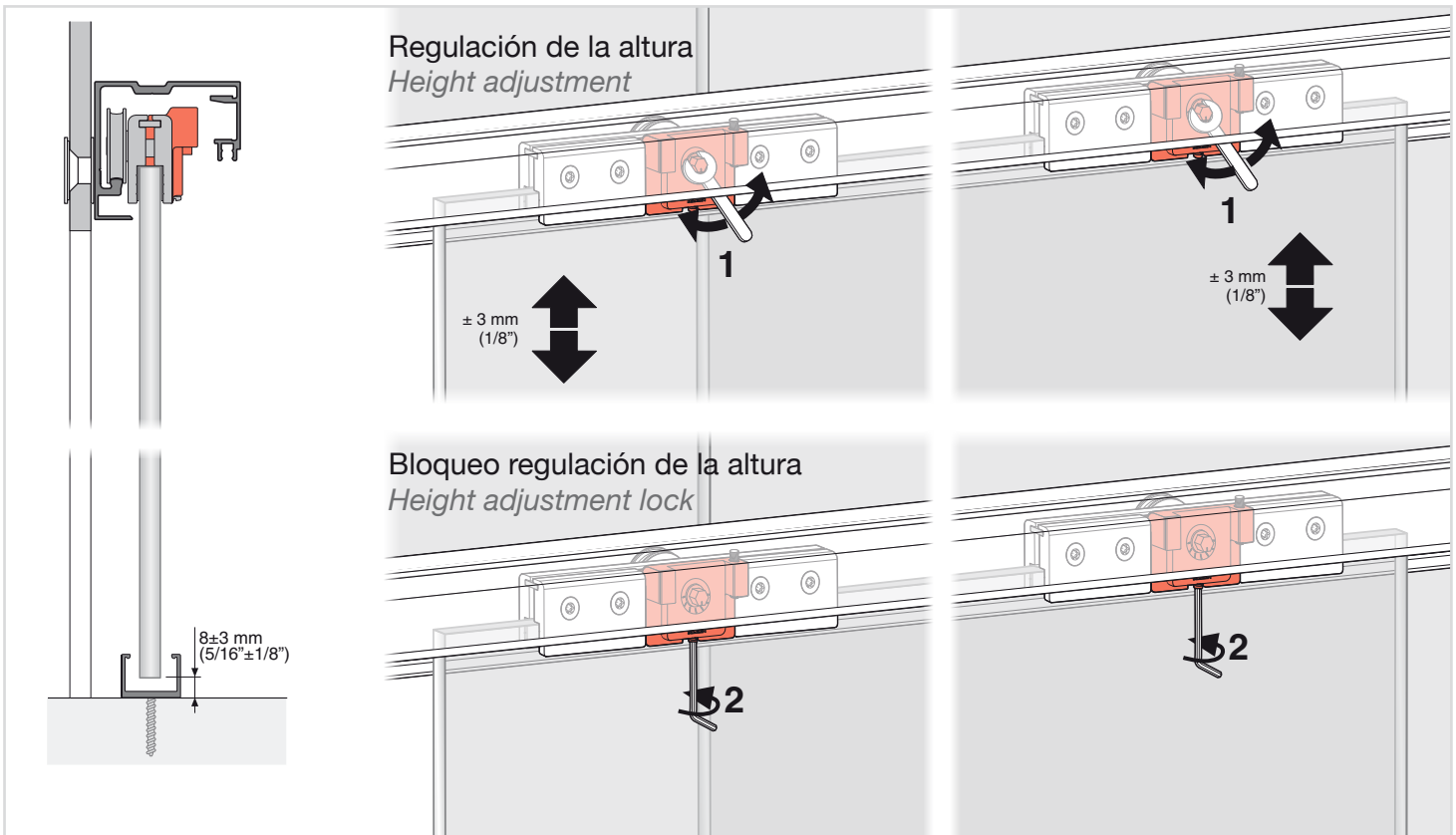

# 12 ANTIDESCABALGAMIENTO / ANTI-JUMP

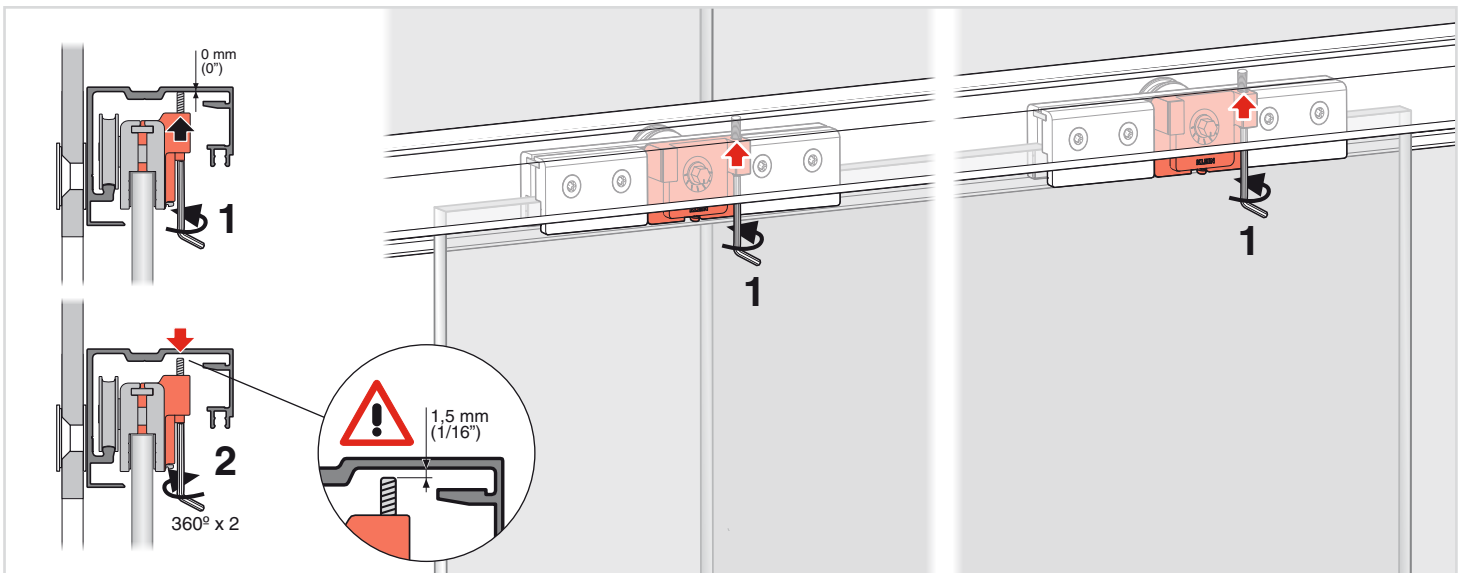

## / BOTTOM STOPPERS INSTALL

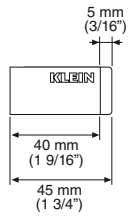
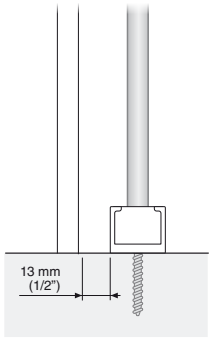

### BOLSA / BAG 6

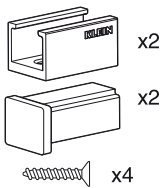

Ajuste final mediante el coliso  
Final adjustment through the slotted hole

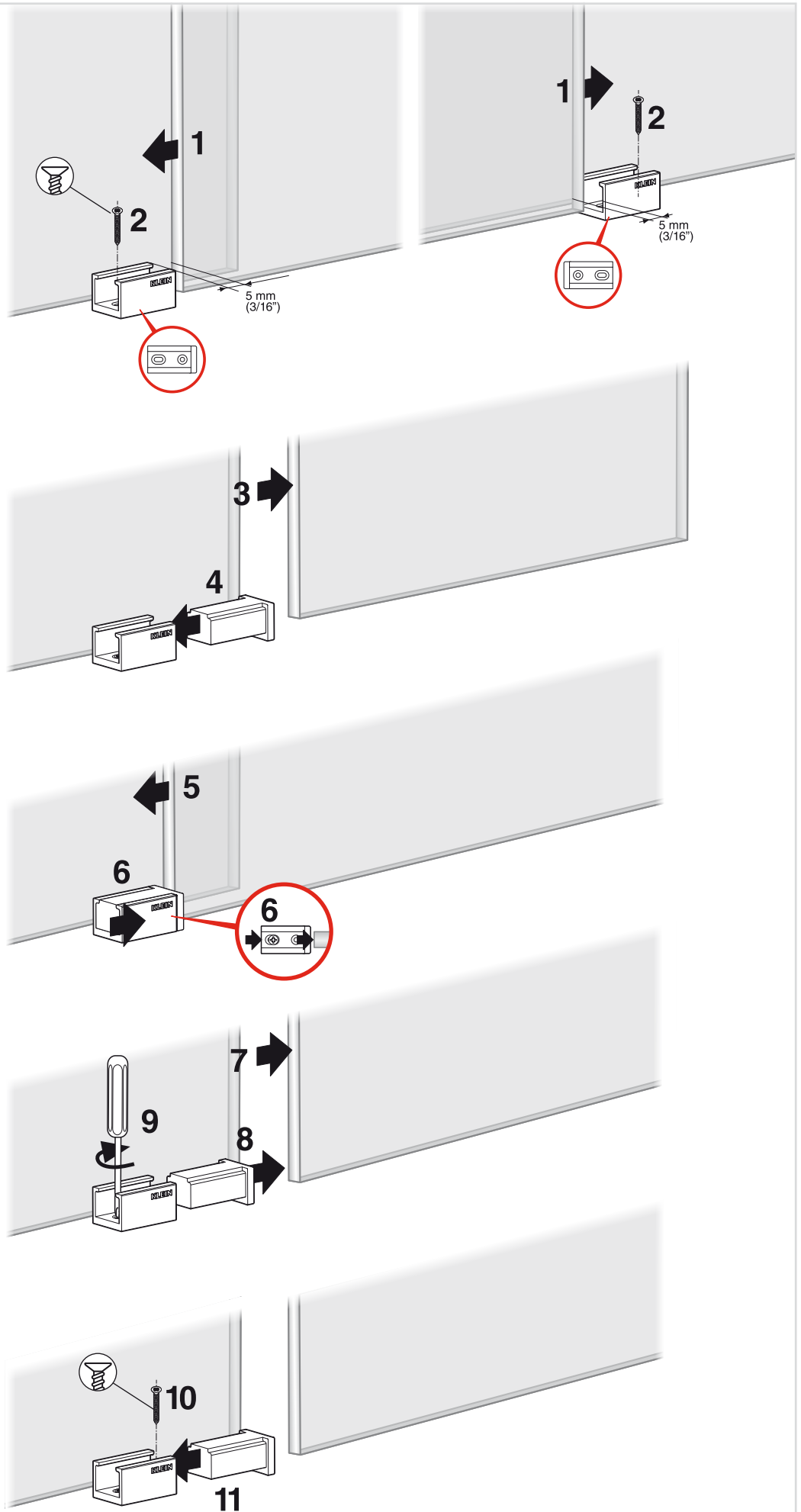

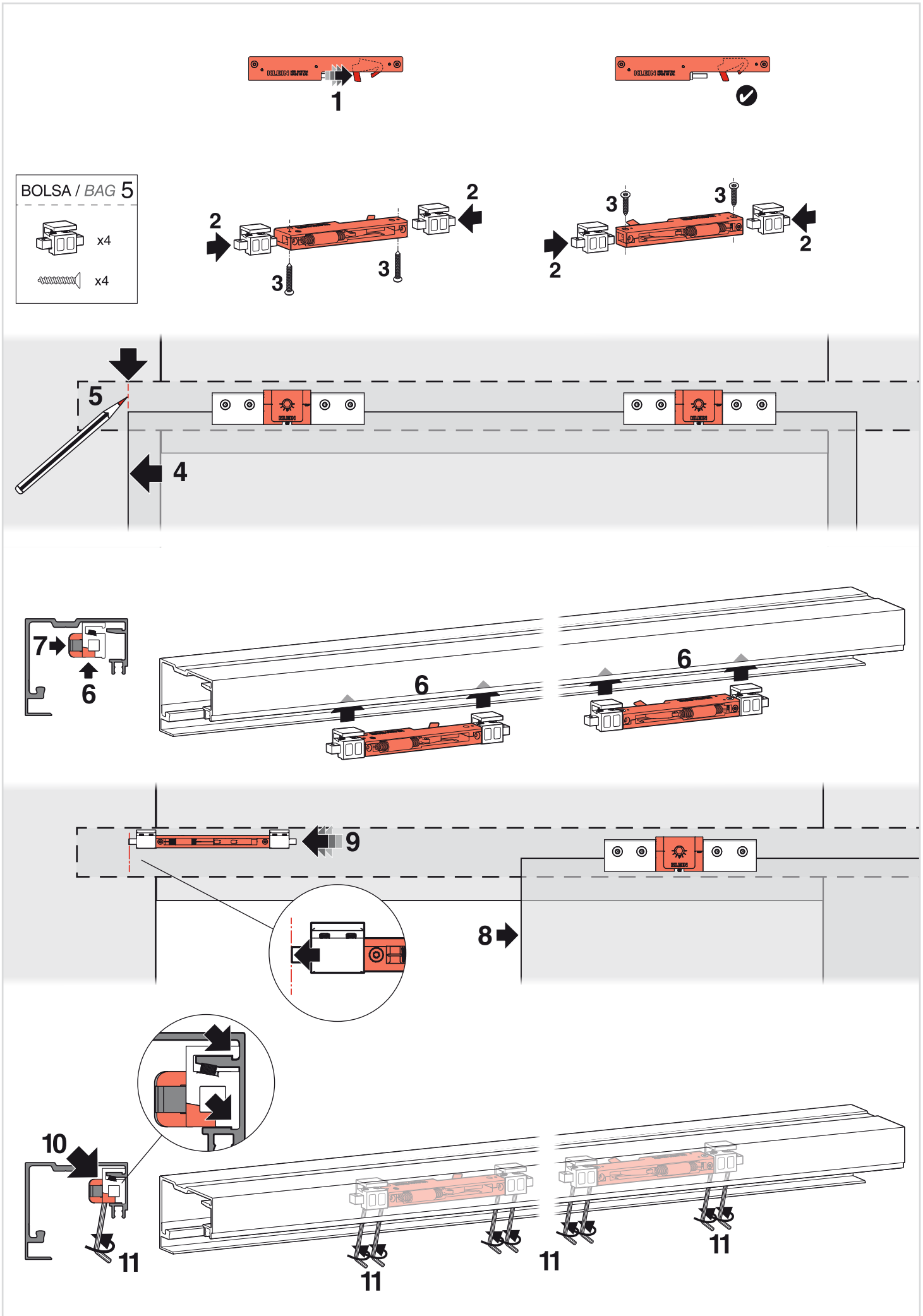

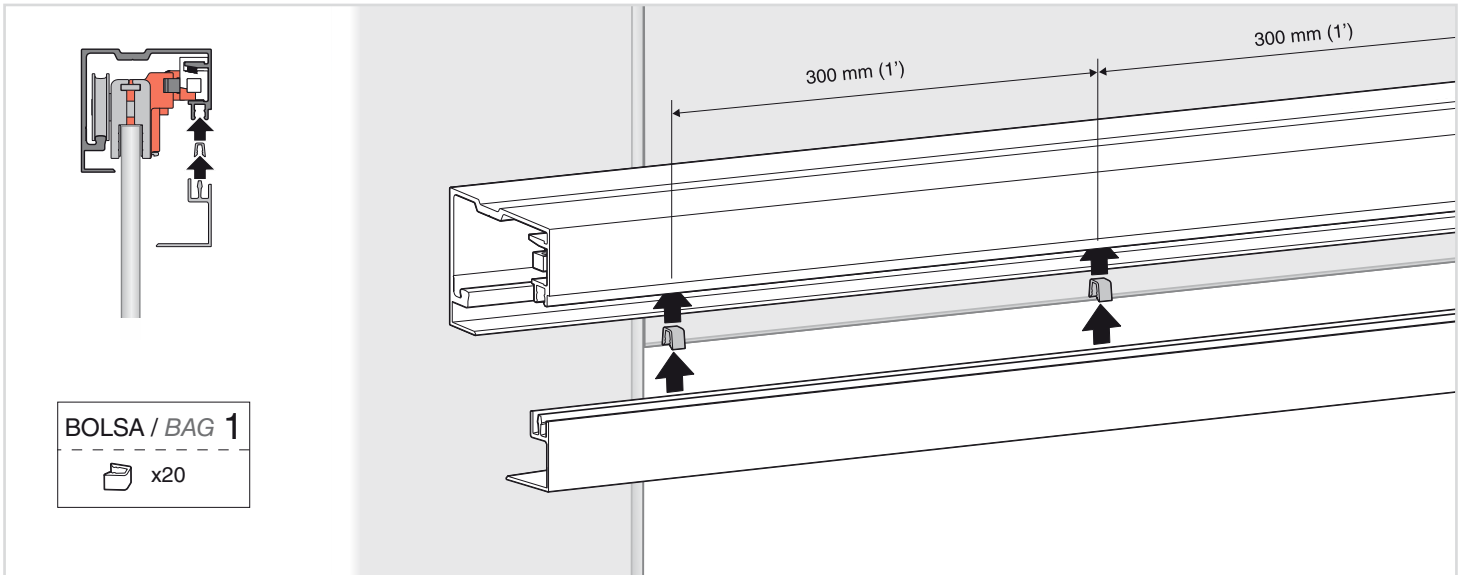

16 COLOCACIÓN DE LAS TAPAS LATERALES  
END CAP INSTALL

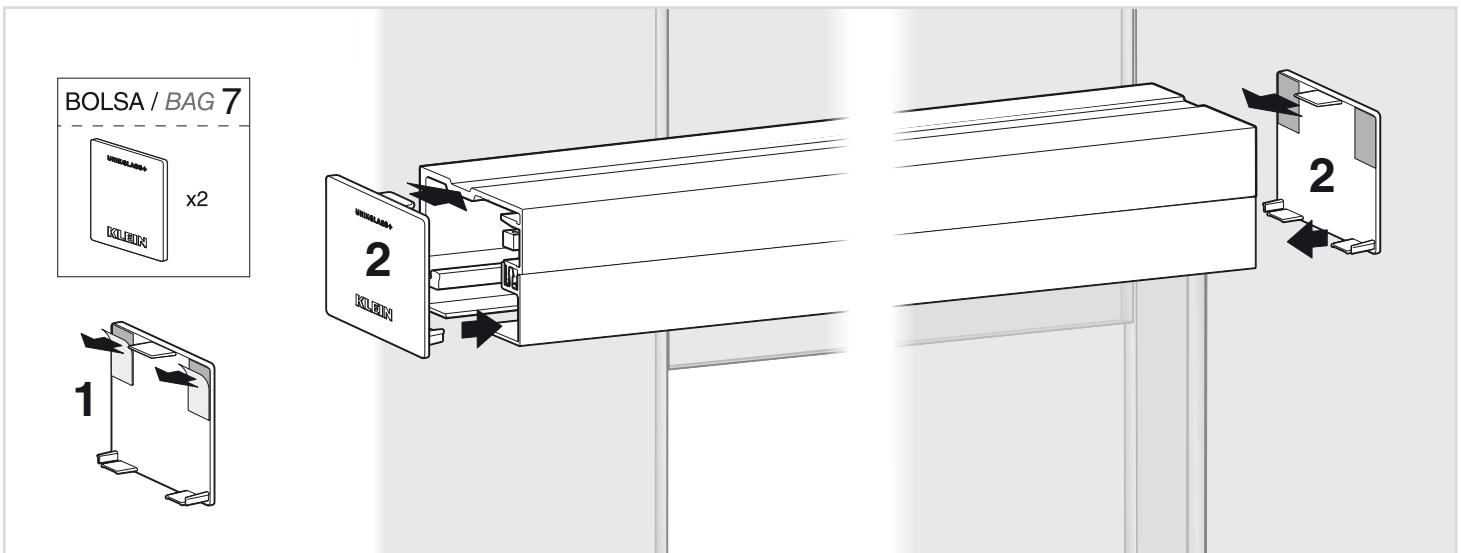





**KLEIN**

**KLEIN EUROPE** - Edificio KLEIN, Polígono Industrial Can Cuyás, N-150 Km.1  
08110 Montcada i Reixac (Barcelona-Spain)  
Tel.: (+34) 935 751 010 - Fax: (+34) 935 760 109 - +INFO: [www.klein-europe.com](http://www.klein-europe.com)

