

TV LIFTER

System instruction

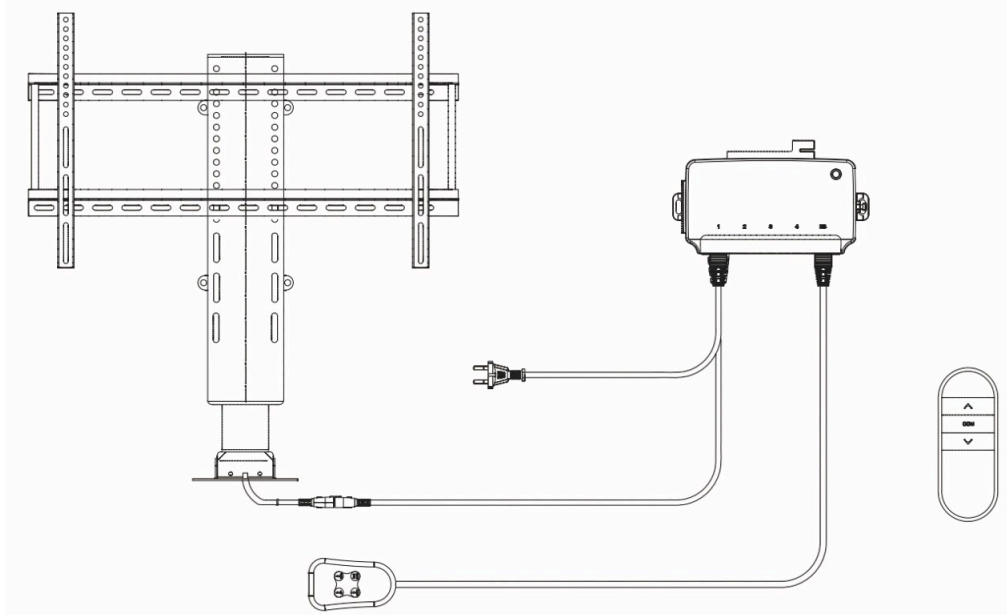

TV lifting mounting system diagram



No.1: VT system diagram

Specification

- Input Voltage: 110V/230V wide voltage
- Overloading Protection: Over Current protection 8.5A
- Standard Stroke Length Mounting Distance: 650mm/1000mm; 570mm/810mm
- Remote control Frequency: 2.4GHZ, Strong Diffraction Ability
- Remote control distance: $\leq 5m$, No barrier .Stereoscopic space
- Hand controller: Continuous-touch to go up and down Easy switch from one-touching to continuous touching. During RESET, one-touching is active.
- Max loading capacity: 60kg
- No-loading Speed: 30mm/s

Function description

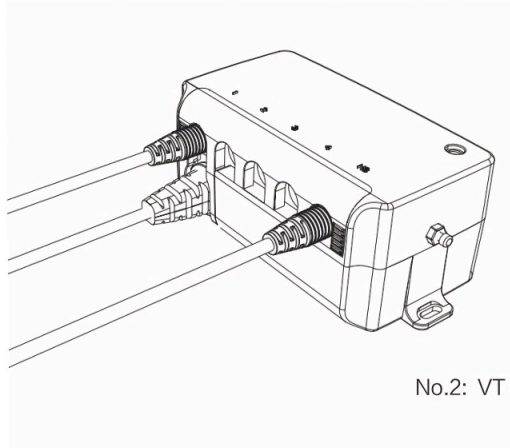

No.2: VT control box partial connection diagram

Control box partial wiring instruction:

Connect Hand controller 9 pin plug with HS port in control box. Connect Lifter 5 pin plug with 1st port in control box. Ports No.2-4 are currently blocked for usage.

1、 RESET:

When the red light signal that indicates the system is at reset position, system have to complete RESET in order to operate . Reset flash interval time is about 0.5s which differs from protection flash when working. By the way, the flash time interval is 3s for working protection.

Detailed operation as follow:

Press the reset button to lower lifter all the way to the bottom. After that, lifter would rise 7mm and light shuts down. Then, RESET is complete. During the whole process, RESET button cannot be released. Meanwhile, the LED light on the hand controller would flash quickly. When light turns off, it means the RESET is done.

Note 1:

- ① Before RESET is complete, all buttons are not functionally working except RESET button on the hand controller.
- ② Press RESET button 5s in order to activate RESET position intentionally.
- ③ When lifter is working, press RESET would stop it. If press RESET at least 5s, the TV lifter would come into RESET automatically.

2、 Studying:

Before using remote controller, it is necessary for remote controller to process studying:

Press \wedge + \vee on the remote controller as well as STUDY button on the hand controller simultaneously. Once it is , LED light would flash three times, which indicates studying is complete. Study button cannot be released until the studying process is complete.

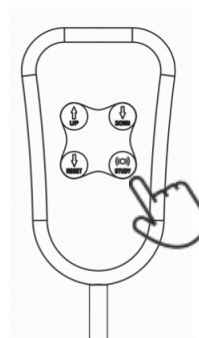
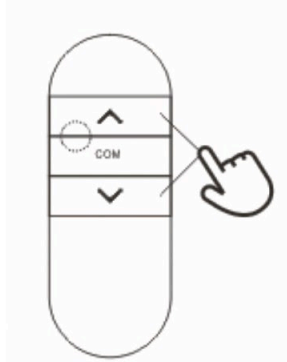

No.3: Remote controller studying diagram

After completion of studying and reset, following function can be achievable:

3、 Remote function:

- Press \wedge :

Continuous touching mode: lifter would go up continuously, press any button to stop it or at upper limit spot.

One-touching mode: Press up button to rise, release button to stop.

- Press  :

Continuous touching mode: lifter goes down. Press any button to stop it or at lower limit spot;

One touching mode: press button to go down, release button to stop;

- COM button: switch continuous touching or one touching mode:
Hold com button 10s to switch from continuous touching to one touching, vice versa. When switch is conducted successfully, the red light on the remote controller would flash to signal.

“Com” function of power-down memory. After power-down, the “com” setting is still valid.

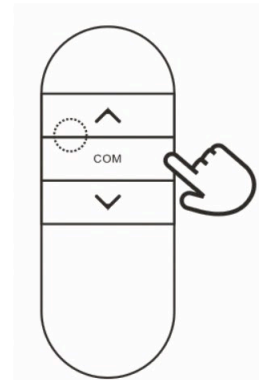

No.4: Remote one-touching, continuous-touching switch operation diagram

4、Hand controller function:

- UP button: Press button, lifter would go all the way up to upper limit position. During rising, press button again to stop;
- Down button: Press button, lifter would go all the way down to lower limit position. During declining, press button again to stop;
- To set the upper-limit position: Hold the UP and RESET for 3 seconds, release the button to stop rising column, the position column stops is the upper limit;
- To set the lower-limit position: Hold the UP and RESET for 3 seconds, release the button to stop descending column, the position column stops is the lower limit;

The upper and lower limit set has power down memory, which means the setting still remains even if it powers off and re power.

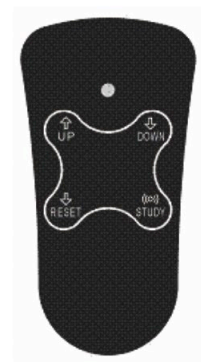

5、Working system protection

If column keeps continuous operation for 3 minutes, it will enter working protection state. All buttons do not work during the process. It will back to normal operation after 16 minutes. When the system enters work protection, the indicator light flash once every 3 seconds.

6、The priority of the handset is higher than the remote controller

- When the actuator was found abnormal travel, you can reset as following way: hold the RESET button on the handset 5s, small light flashes and enter the reset state, other buttons do not work, you need to press the RESET button to reset.
- When the actuator occurs over-current protection, it will stop but not show an error. Then release the button, it can still operate normally.
- When the feedback signal of actuator is disconnected, or the plug drops out during operation, the actuator will stop and the small light keeps flashing. Then it enters the reset state and need to be reset.
- During normal operation, the system power failure will not trigger reset operation.