

INSTALLATION.

1.

Mark position of cut out on door, ensuring that cam in locked position will fit into keep or strike plate of door frame.

Cut out door as dimensioned below. Cut must be clean and smooth free from burrs.

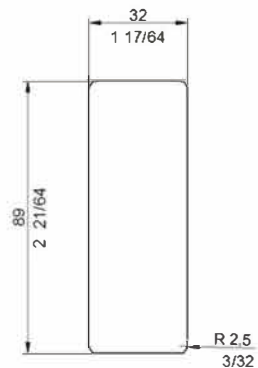

2.

Position the handle frame onto the lock from the rear. Insert the lock together with handle into the door cut out. See diagram below:

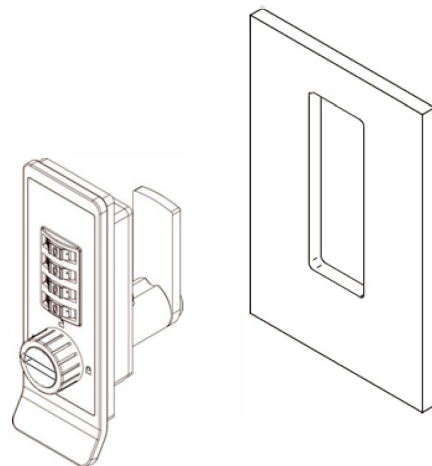

3.

The lock as standard is supplied with two length of fixing screws that will allow the lock to be fitted to doors between 12mm (15/32") and 20mm (3/4"). Should doors be thinner than 12mm (15/32") then packing pieces can be supplied (sold separately). Please see sizing chart below to select the correct screws to fit door thickness and if packing piece is required.

Door Thickness	Pad Thickness	L Screw
1 mm (3/64")	5 mm (13/64"), 10 mm (3/8")	25 mm (1")
2 (5/65") to 4 mm (5/32")	10 mm (3/8")	20 mm (3/4")
5 (13/64") to 6 mm (15/64")	10 mm (3/8")	25 mm (1")
7 (9/32") to 9 mm (23/64")	5 mm (13/64")	20 mm (3/4")
10 (3/8") to 11 mm (7/16")	5 mm (13/64")	25 mm (1")
12 (15/32") to 14 mm (35/64")	0	20 mm (3/4")
15 (19/32") to 20 mm (3/4")	0	25 mm (1")

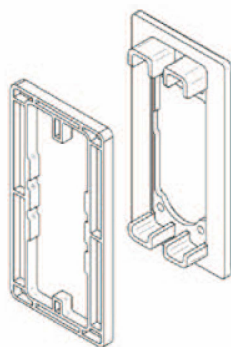

Fastening Plate Pad

4.

Fit lock to door, placing fixing plate onto the inside of the door. See diagram below:

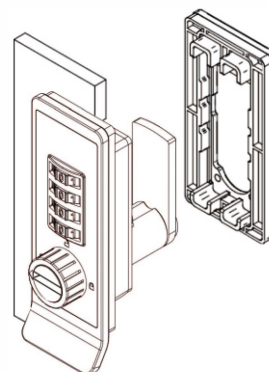

5.

Secure the lock to the door using correct length fixing M3 screws from inside of the door. See diagram below:

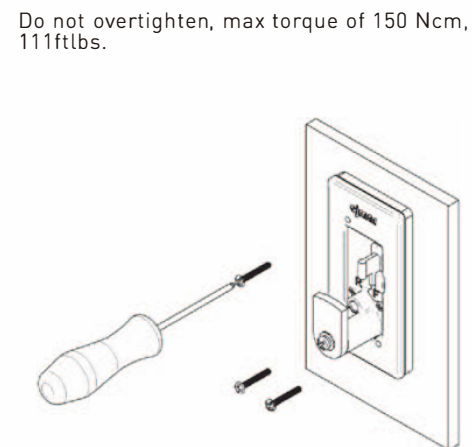

Do not overtighten, max torque of 150 Ncm, 111ftlbs.

ojmar®

INTELLIGENT LOCKING SYSTEMS

MENGUAL®

LOCKR COMBI

LOCK 8001

INSTALLATION GUIDE v 0.2



HOW TO CONVERT A RIGHT HAND (RH) LOCK TO A LEFT HAND LOCK (LH).

IMPORTANT!

Please note all locks are supplied as standard as RH. (See diagram below) If LH locks are required please change hand before fitting.

Before converting to a LH lock please ensure key cylinder is inserted.

1.

Ensure that the lock is in the open position with the cam and the blue indicator in the unlocked position. See diagram below:

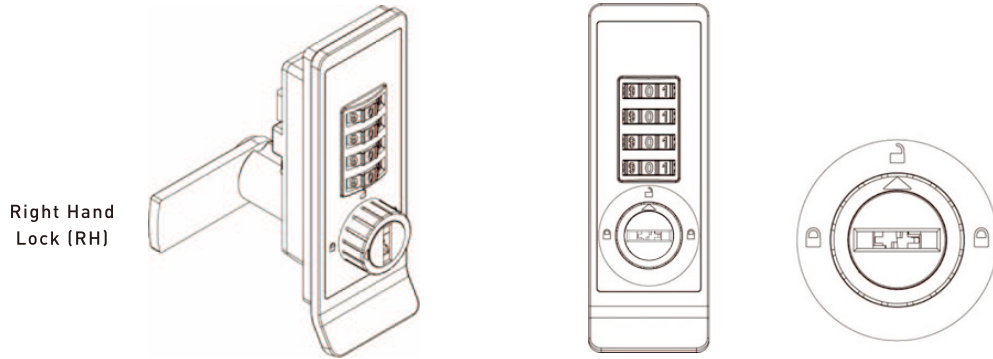

3.

Remove end cap.

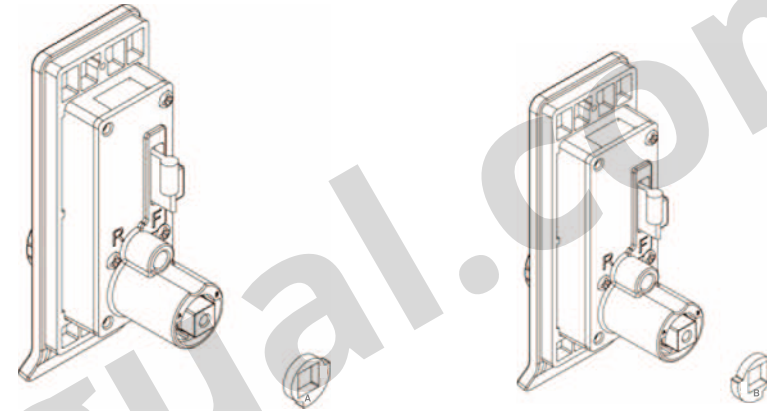

4.

Turn end cap horizontally 180° and replace. Please note position of end cap. See diagram below:

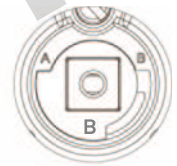

Note position of end cap in place for LH operation

2.

Unscrew the fixing screw from the cam, removing both the cam and washer. Do not turn. Please note position of end cap. See diagram below:

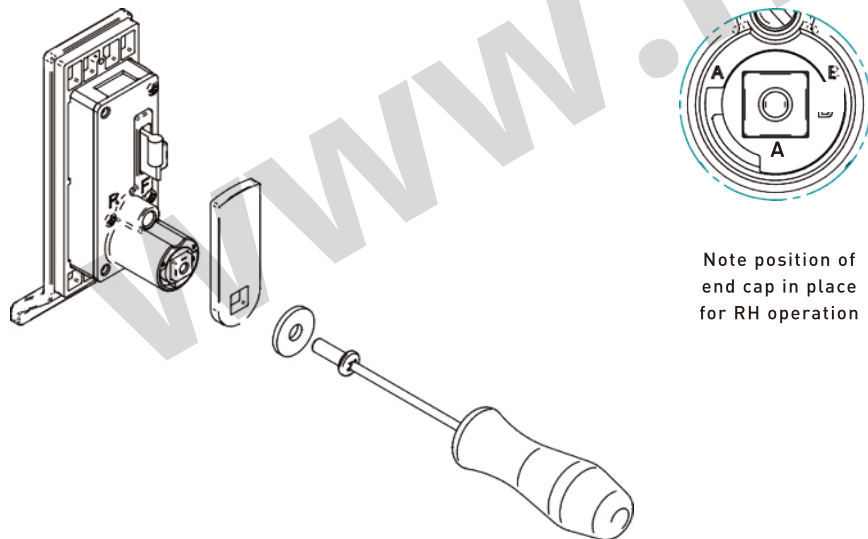

5.

Refit cam and washer in the open vertical position. The lock will now work for LH operation. See diagram below:

